

Revision B 2023-02

INSTRUCTION MANUAL

Original Instructions

10" Cabinet Table Saw

MODEL:HW110LC-36

HW110LC-36P



Contents

1. Foreword	1
2. Warranty Information	1
3. Machine Description	2
3.1 Technical Parameters	2
3.2 Features Identification	5
3.3 Optional Equipments	5
3.4 Intended Use	6
3.4 Requirements of Electrical Power	6
4. Safety Regulations	7
4.1. General Safety Instructions	7
4.2. Specific Safety Instructions for Sliding Table Saw	7
4.3. Residual Risks	8
4.4. Safety Equipments	8
5. Installation of the Machine	9
5.1 Transportation of Machines	9
5.2 Unpacking	9
5.3 Contents	10
5.4 Installation	12
6. Adjustment	20
6.1 Adjusting the Rip Fence	20
6.2 Aligning the Table T-slot Parallel with Blade	20
6.3 Adjusting the 45° and 90° Positive Stops	20
6.4 Aligning the Riving Knife with Blade	21
7. Operations	22
7.1 Electrical Operation	22
7.2 Blade Elevation and Tilting Adjustment	22
7.3 Crosscutting	22
7.4 Ripping	23
8. Maintenance	23
9. Trouble Shooting	24
10. Exploded View and Parts List	25
11. Certificates	34

1. Foreword

This manual contains basic information for qualified operating staff and describes the surroundings and using ways of the machine for those it is intended. It contains also all necessary information for a correct and safe operating. The machine is equipped with various safety equipment protecting operator and machines well at usual technological using. These regulations, however, cannot sheet all other safety aspects. That is why operator must peruse and make sense of this manual before starting of machine use. Installation and operation mistakes will be foreclosed herewith.

Do not try to start the machine before having read all instructions manual delivered with the machine and understood every function and technique.

2. Warranty Information

Limited Warranty

Two years.

Proof of Purchase

Please keep your dated proof of purchase for warranty and servicing purposes.

Limited Tool Warranty

We make every effort to ensure that this product meets high quality and durability standards. We warrant that this product is free from manufacturing defects for two-year under the terms of a limited warranty. The two-year term begins at the time of the retail purchase. This warranty does not apply to defects due directly or indirectly to misuse, abuse, normal wear and tear, negligence or accidents, repairs done by an unauthorized service center, alterations or lack of maintenance. We shall in no event, be liable for death, injuries to persons or property or for incidental, special or consequential damages arising from the use of our products. To take advantage of this limited warranty, contact with your local distributor or our customer service center. After examination, we will repair or replace the product or any part(s) covered under this warranty due to defective workmanship or material(s) during the warranty period.

WARNING

Notice to California Residents: This product can expose you to wood dust, which is known to the State of California to cause cancer. For more information, go to www.P65Warnings.ca.gov.

3. Machine Description

3.1 Technical Parameters

For North American Market:

ITEM		HW110LC-36 / HW110LC-36P
Product Dimensions	Weight	411 lbs
	Length/Width/Height	70-3/4" x 49-3/4" x 48-1/4" (1795x1265x1225 mm)
	Footprint	20-1/4" x 19-5/8" (514x498 mm)
Switch	Switch type	Magnetic with Thermal Overload Protection
	Standard	UL62841
Motor	Type	TEFC, Capacitor Start, Induction
	Horsepower, Voltage, Phase, Amps	2.0 HP, 115 V, 1 PH, 16 A
		2.0 HP, 230 V, 1 PH, 8 A
	Speed	3500 RPM
Power Transfer	V-Ribbed Belt Drive	
Blade Information	Maximum Blade Diameter	10" (254 mm)
	Riving Knife Thickness	0.1"(2.5 mm)
	Available Blade Plate Thickness	0.071"-0.094" (1.8-2.4 mm)
	Available Blade Kerf Thickness	0.102"-0.126" (2.6-3.2 mm)
	Maximum Width of Dado	13/16"(20.6mm)
	Blade Tilt	Left 0-45°
	Arbor Diameter at Blade	5/8" (15.875 mm)
	Arbor Speed	3850 RPM
	Arbor Bearings	Sealed and Permanently Lubricated
Cutting Capacities	Maximum Depth of Cut at 90°	3-1/8"(79.4 mm)
	Maximum Depth of Cut at 45°	2-3/16"(55.5 mm)
	Maximum Rip, Right of Blade	36"(915 mm)
	Maximum Rip, Left of Blade	9"(228 mm)
Table Information	Height	34"(867 mm)
	Main Table - Length/Width/Thickness	31.49" x 22.44" x 1.83"(800x570x46.5 mm)
	Distance Between the Front Edge of Table to Center of Blade	18.9"(480 mm)
Miter Gauge	Miter Gauge Slot Type	T-Shape
	Miter Gauge Size - Width/Height	3/4" x 3/8"(19.05x9.5 mm)
Blade Guard	Blade Guard Type	GLIDER Saw Blade Guard
Fence	Fence Type	T-Square High and Low Fence
	Fence Size	3-3/8" x 1-7/8" (85.5 x 48.5 mm)
Other Information	Finishing	Powder Coated
	Dust Port Size	4"(100 mm)

Note:

ALPHA Series table saws have two types:

- HW110LC-36 : TiN coated cast iron table
- HW110LC-36P : Precision ground cast iron table

For European Market:

	ITEM	HW110LC-36 / HW110LC-36P
Product Dimensions	Weight	186.5 kg
	Length/Width/Height	1795x1265x1225 mm
	Footprint	514x498mm
Switch	Switch type	Magnetic with Thermal Overload Protection
	Standard	CE
Motor	Type	TEFC, Capacitor Start, Induction
	Horsepower, Voltage, Phase, Amps	1.65 kW, 220 V, 1 PH, 10 A
	Speed	2900 RPM
	Power Transfer	V-Ribbed Belt Drive
Blade Information	Maximum Blade Diameter	254 mm
	Riving Knife Thickness	2.5 mm
	Available Blade Plate Thickness	1.8-2.4 mm
	Available Blade Kerf Thickness	2.6-3.2 mm
	Maximum Width of Dado	20.6 mm
	Blade Tilt	Left 0-45°
	Arbor Diameter at Blade	30 mm
	Arbor Speed	3850 RPM
	Arbor Bearings	Sealed and Permanently Lubricated
Cutting Capacities	Maximum Depth of Cut at 90°	70 mm
	Maximum Depth of Cut at 45°	50 mm
	Maximum Rip, Right of Blade	915 mm
	Maximum Rip, Left of Blade	228 mm
Table Information	Height	867 mm
	Main Table - Length/Width/Thickness	800x570x46.5 mm
Miter Gauge	Miter Gauge Slot Type	T-Shape
	Miter Gauge Size - Width/Height	19.05x9.5 mm
Blade Guard	Blade Guard Type	CE Version Saw Blade Guard
Fence	Fence Type	T-Square High and Low Fence
	Fence Size	85.5 x 48.5 mm
Other Information	Finishing	Powder Coated
	Dust Port Size	100 mm

Note:

ALPHA Series table saws have two types:

- HW110LC-36 : TiN coated cast iron table
- HW110LC-36P : Precision ground cast iron table

For Asian Market:

	ITEM	HW110LC-36 / HW110LC-36P
Product Dimensions	Weight	186.5 kg
	Length/Width/Height	1795x1265x1225 mm
	Footprint	514x498 mm
Switch	Switch type	Magnetic with Thermal Overload Protection
	Standard	CE
Motor	Type	TEFC, Capacitor Start, Induction
	Horsepower, Voltage, Phase, Amps	1.65 kW, 220 V, 1 PH, 10 A
	Speed	2900 RPM
	Power Transfer	V-Ribbed Belt Drive
Blade Information	Maximum Blade Diameter	254 mm (10")
	Riving Knife Thickness	2.5 mm
	Available Blade Plate Thickness	1.8-2.4 mm
	Available Blade Kerf Thickness	2.6-3.2 mm
	Maximum Width of Dado	20.6 mm
	Blade Tilt	Left 0-45°
	Arbor Diameter at Blade	15.875 mm
	Arbor Speed	3850 RPM
	Arbor Bearings	Sealed and Permanently Lubricated
Cutting Capacities	Maximum Depth of Cut at 90°	79.4 mm
	Maximum Depth of Cut at 45°	55.5 mm
	Maximum Rip, Right of Blade	915 mm
	Maximum Rip, Left of Blade	228 mm
Table Information	Height	867 mm
	Main Table - Length/Width/Thickness	800x570x46.5 mm
Miter Gauge	Miter Gauge Slot Type	T-Shape
	Miter Gauge Size - Width/Height	19.05x9.5 mm
Blade Guard	Blade Guard Type	GLIDER Saw Blade Guard
Fence	Fence Type	T-Square High and Low Fence
	Fence Size	85.5 x 48.5 mm
Other Information	Finishing	Powder Coated
	Dust Port Size	100 mm

Note:

ALPHA Series table saws have two types:

- HW110LC-36 : TiN coated cast iron table
- HW110LC-36P : Precision ground cast iron table

3.2 Features Identification

Refer to **Fig. 1**.

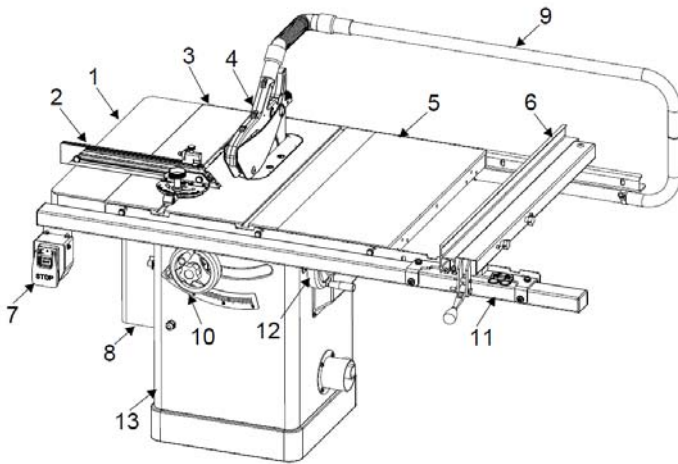

Fig. 1

- 1 Left Extension Wing
- 2 Miter Gauge
- 3 Main Table
- 4 Blade Guard
- 5 Right Extension Wing
- 6 Fence
- 7 On/Off Switch
- 8 Motor Cover
- 9 Over Arm Dust Collection (system)
- 10 Blade Elevation Hand Wheel
- 11 Rail & Tube
- 12 Blade Tilt Hand Wheel
- 13 Cabinet

NOTE:

Fig.1 is only for illustration, and the actual object shall prevail.

3.3 Optional Equipment

Sliding table

Model: ST-1400S

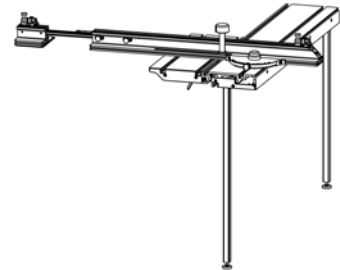

Fig. 1-1

Universal Overhead Guard

Model: S-12S

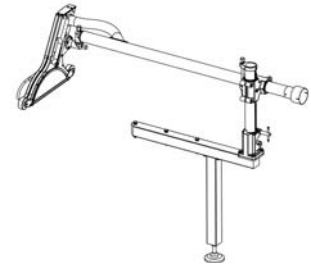

Fig. 1-2

Universal Mobile Base

Model: MB-600

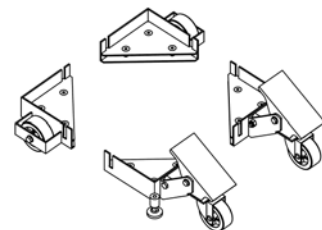

Fig. 1-3

3.4 Intended Use

This table saw and the workpiece guide equipment supplied with it are intended to be used exclusively for the following purposes:

- Laminated and unlaminated board materials (e.g. chipboard, coreboard, MDF board, ...)
- Solid wood
- Gypsum plasterboard, Cardboard, Veneer with a suitable clamping device
- Dimensionally stable plastics (thermoset plastics, thermoplastics).

Tools:

- The chosen saw blade must be suitable both for the specific work cycle and for the specific material.
- Only circular blades which are solid chrome vanadium (CV) or tungsten carbide tipped (TCT) and have a diameter of 254mm (10"), arbor size of 15.875 mm (5/8") or 30mm, as well as a maximum mounting width of 20.3 mm are allowed for the main saw.

Site of installation / use:

- The machine is not suitable for use outdoors, or in rooms that are subject to moisture or the risk of explosions.
- The intended use of the machine involves connection to a suitably dimensioned dust extraction system .
- Intended use also involves compliance with our specified operating, maintenance and repair conditions and the safety information contained in the operating instructions.
- The table saw may only be used, set up and maintained by persons who are familiar with the machine and aware of the dangers.
- The pertinent accident prevention regulations as well as any other generally recognized technical safety and industrial health rules must be observed.
- Repair work must be carried out by our own customer service or by an authorized repair center. Only original spare parts are allowed to be used on this machine. We will assume no warranty for any damage that is caused by using non-original spare parts.

WARNING

The machine is prohibited to be used in a potentially explosive atmosphere!

3.5 Requirements of Electrical Power

List of the motor using & pre-wired voltage

Item	Motor	
	2 HP	2 HP(1.65 kW)
Voltage(V)	115 / 230V	230 V
Phase	1 Ph	1 Ph
Freq.(Hz)	60 Hz	50 Hz
Nominal current A	16 / 8 A	10 A
Pre-wired	115 V / 1Ph	230 V / 1 Ph
Cords	3	3
Circuit Breaker	20 A	20 A

WARNING

To avoid the accidental injury and damage to the machine, please check the name plate of the machine carefully to identify the power supply demand of the machine.

The Circuit Breaker with RCD module shall be installed for supplying electric power to this machine, in order to protect people against electrical shock due to indirect shock.

4. Safety Regulations

4.1 General Safety Instructions

1. KNOW YOUR MACHINE.

Read and understand the owner's manual and labels affixed to the machine. Learn its application and limitations as well as its specific potential hazards;

2. GROUND THE MACHINE.

In the event of an electrical short, grounding reduces the risk of electrical short;

3. KEEP THE BLADE GUARDS IN PLACE.

Keep in good working order, properly adjusted and aligned;

4. REMOVE THE ADJUSTING TOOLS

Form a habit of checking that the key and adjusting wrenches are removed from the machine before turning it on;

5. KEEP THE WORK AREA CLEAN.

Cluttered areas and benches invite accidents. Make sure the floor is clean and not slippery due to wax and sawdust build-up;

6. AVOID A DANGEROUS ENVIRONMENT.

Don't use machines in damp or wet locations or expose them to rain. Keep the work area well lit and provide adequate surrounding work space;

7. KEEP CHILDREN AWAY.

All visitors should be kept a safe distance from work area;

8. MAKE WORKSHOP CHILD-PROOF.

With padlocks, master switches or by removing starter keys;

9. USE THE PROPER SPEED.

A machine will do a better and safer job when operated at the proper speed;

10. USE THE RIGHT MACHINE.

Don't force the machine or the attachment to do a job for which it was not designed;

11. WEAR THE PROPER APPAREL.

Do not wear loose clothing, gloves, neckties or jewelry (rings, watch) because they could get caught in moving parts. Non-slip footwear is recommended. Wear protective hair covering to contain long hair. Roll up long sleeves above the elbows;

12. MAINTAIN PROPER FOOTING.

Keep proper footing and balance at all time. Do not over-reach to perform an operation;

13. MAINTAIN THE MACHINE WITH CARE.

Keep tools sharp and clean for the best and safest performance;

14. DISCONNECT MACHINES.

Before servicing, when changing accessories or attachments;

15. AVOID ACCIDENTAL STARTING.

Make sure the switch is in the "OFF" position before plugging in;

16. USE RECOMMENDED ACCESSORIES.

Consult the manual for recommended accessories. Follow the instructions that accompany the accessories. The use of improper accessories may cause hazards;

17. NEVER STAND ON THE MACHINE.

Serious injury could occur if the machine tips over. Do not store materials such that it is necessary to stand on the machine to reach them;

18. CHECK FOR DAMAGED PARTS.

Before further use of the machine, a guard or other parts that are damaged should be carefully checked to ensure that they will operate properly and perform their intended function. Check for alignment of moving parts, breakage of parts, mounting, and any other conditions that may affect its operation. A guard or other parts that are damaged should be properly repaired or replaced;

19. NEVER LEAVE THE MACHINE RUNNING UNATTENDED.

Turn the power to "off". Do not walk away from the machine until it comes to a complete stop;

20. ADEQUATE LIGHT

Ensure that adequate general or localized lighting is provided in work area;

4.2 Table Saw Safety Instructions

1. ALWAYS USE A GUARD.

Always use a guard, splitter on all "thru-sawing" operations. Thru-sawing operations are those when the blade cuts completely through the work piece as in ripping or crosscutting;

2. ALWAYS HOLD THE WORK.

Always hold the work firmly against the miter gauge or fence;

3. ALWAYS USE A PUSHSTICK OR PUSH BLOCKS.

Push blocks or push sticks shall be used when cutting small workpieces and in circumstances where it is necessary to push the workpiece against the fence;

4. NEVER PERFORM UNSAFE OPERATIONS.

Never perform any operations "free-hand" which means using your hands to support or guide the work piece. Always use either the fence or the miter gauge to position and guide the work piece;

5. STAND TO THE SIDE WHEN FEEDING MATERIAL.

Never stand or have any part of your body in line with the path of the saw blade;

6. USE CAUTION WHEN REACHING FOR OBJECTS.

Never reach behind or over the cutting tool with either hand for any reason;

7. SAFE CROSSCUTTING OPERATIONS.

Move the rip fence out of the way when crosscutting;

8. ENSURE CORRECT FEEDING OF MATERIAL.

Feed the work into the blade against the direction of rotation;

9. CORRECT USAGE WITH THE FENCE.

Never use the fence as a cut-off gauge when you are cross-cutting;

10. ALWAYS TURN THE POWER TO THE "OFF" POSITION.

When attempting to free a stalled saw blade, always turn the saw to the "off" position;

11. PROVIDE ADEQUATE SUPPORT.

To the rear and sides of the table saw for wide or long work pieces;

12. AVOID KICKBACKS.

Avoid kickbacks (work thrown back towards you) by keeping the blade sharp, by keeping the rip fence parallel to the saw blade, by keeping the splitter and guard in place and operating, by not releasing work before it is pushed all the way past the saw blade, and by not ripping work that is twisted or warped or does not have a straight edge to guide along the fence;

13. AVOID AWKWARD OPERATIONS.

Avoid awkward operations and hand positions where a sudden slip could cause your hand to move into the spinning blade;

14. CORRECT SAW BLADE USAGE.

No saw blade shall be used where the maximum marked speed is lower than the maximum rotational speed of the saw spindle;

15. CHIP AND DUST.

The machine shall be connected to an external chip and dust extraction system;

The dust extraction equipment is to be switched on before commencing machining;

4.3 Residual Risks

1. Take precautions to reduce the hazard of inhalation of harmful dust (e.g. wearing a dust mask);
2. Wear ear protection to prevent hearing loss;
3. Always wear safety glasses. Also, use a face or dusk mask if the cutting operation is dusty;
4. Protect against the hazard of being cut when handling saw blades in the machine or while performing maintenance on the machine;
5. Do NOT try to remove chips while the saw is running or the saw blade is moving;
6. Do NOT use the machine unless all of the guards and other safety devices necessary for the particular operation are in good working order and in place.

4.4 Safety Equipment

When cutting narrow workpieces, a Push Block must be used. Push the work piece against the fence if necessary. A push block can be easily made by the operator as shown in Fig. 2.

If the workpieces is less then 4-3/4" (120 mm), you must use the push stick, as shown in Fig.3, to prevent your hands from getting too close to the saw blade.

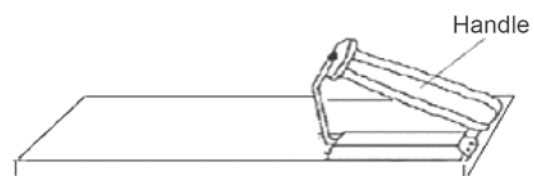

Fig. 2

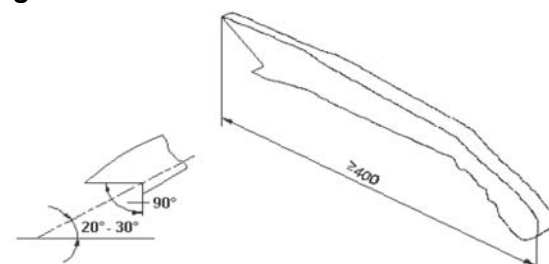

Fig. 3

5. Installation of the Machine

5.1 Transportation of Machines

5.1.1 Transportation and store

This machine has been well packaged and rust preventive measures have been taken at the factory. Care should still be taken to insure that no damage comes from rough handling while moving. Ambient temperatures of -10 to 130 °F (-25 to 55 °C) can be endured by this machine.

Be careful not to expose this machine to rain or other severe weather.

WARNING

While transporting or handling the machine, be careful and let the activity be done by qualified personnel especially trained for this kind of activity!

While the machine is being loaded or unloaded, make sure all persons are out of the way so that no person is crushed by the machine.

Select the proper transportation device according to the weight of the machine. Make sure the lifting capacity of the transportation device is sufficient for the weight of the machine.

5.1.2 Transportation before unpacking

This machine is packed in a robust cardboard box.

Fig. 4 shows the device which can be used to transport the packed crate.



Fig. 4

5.2 Unpacking

Your machine was carefully packaged for safe transportation. Remove the packaging materials from around your machine and inspect it. If you discover that the machine is damaged, please immediately call Customer Service for advice.

Save the containers and all packing materials for possible inspection by the carrier or its agent. Otherwise, filing a freight claim can be difficult.

Note: If you can't find an item on this list, check the mounting location on the machine or examine the packaging materials carefully. Occasionally we pre-install certain components for shipping purposes, or in other packing.

5.3 Contents

The product is packed by four individual boxes as follows:

Main machine box contents: (Fig. 5-1----Fig. 5-4)

A. Main table saw unit.....	1
B. Motor cover.....	1
C. Left extension wing.....	1
D. Extension table (width 365 mm).....	1
E. Saw blade.....	1
F. Blade guard assembly.....	1
F-1 (CE Version saw blade guard)	
F-2 (GLIDER saw blade guard)	
G. Dust Port.....	1
H. Hand wheel.....	1
I. Lock knob.....	1
J. Hex wrench set (eight pieces).....	1
K. Wrench open-end 13/27 mm.....	1
L. Miter gauge.....	1
N. Push stick.....	1
O. Dado table insert.....	1

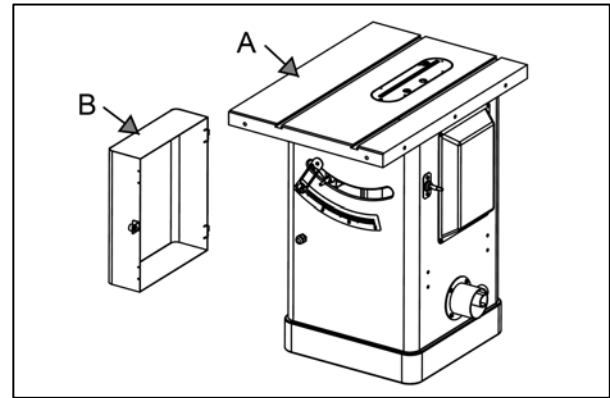

Fig. 5-1

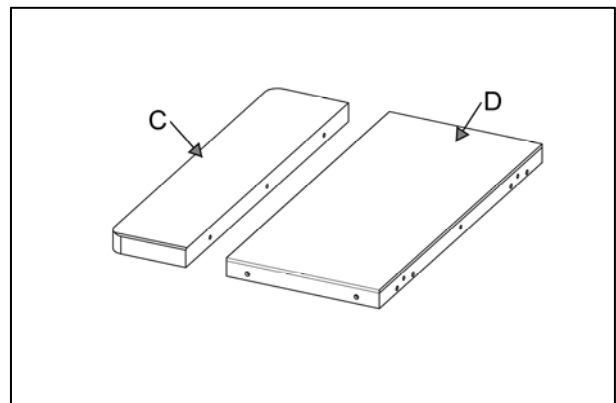

Fig. 5-2

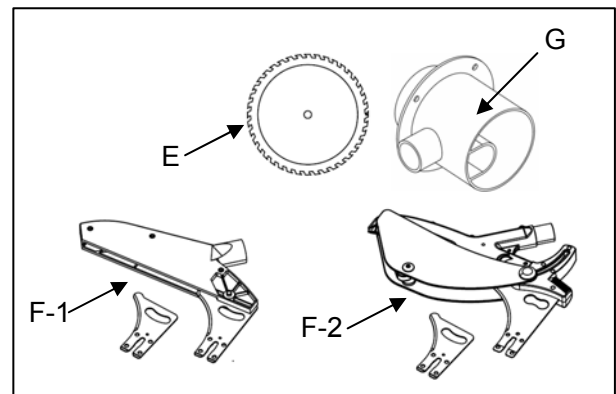

Fig. 5-3

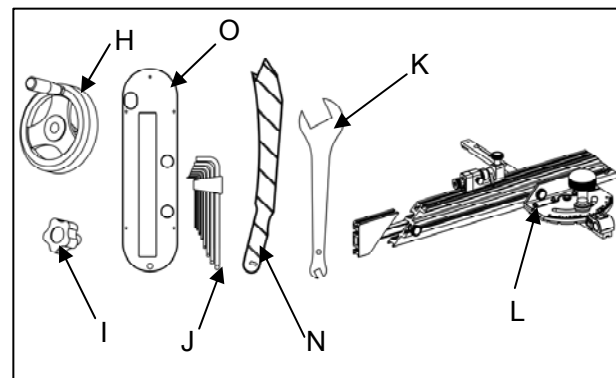

Fig. 5-4

Fence box contents:(Fig. 5-5)

- A. Fence body.....1
- B. Fence.....1

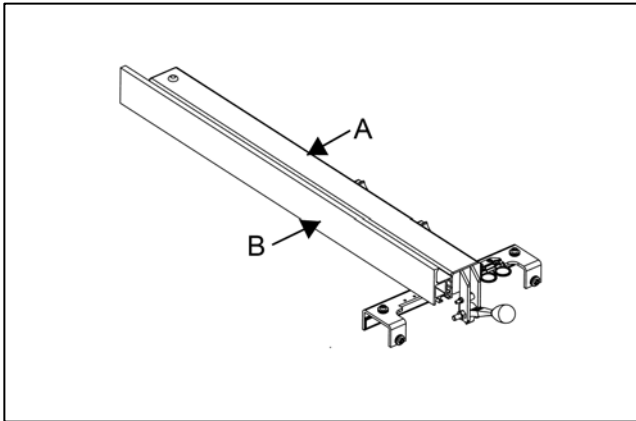

Fig. 5-5

Over arm box contents:(Fig. 5-6)

- A. Over arm.....1
- B. Flexible hose (length 0.6 m).....1
- C. Flexible hose (length 1 m).....1
- D. Bracket.....2

Note:

The assembly contains the corresponding hardware which is not shown in the figure, and can be checked with the exploded view.

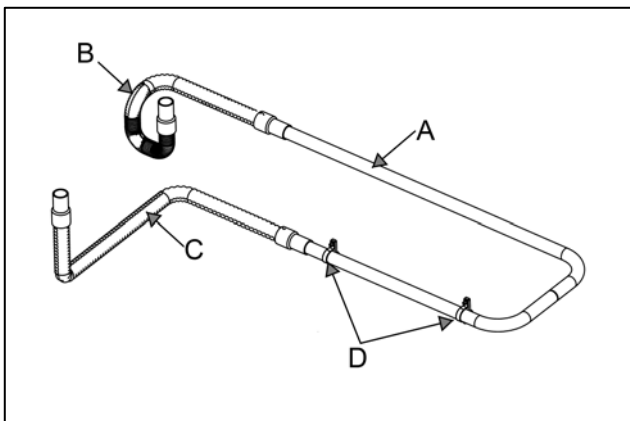

Fig. 5-6

Rail box contents:(Fig. 5-7)

- A. Rear rail.....1
- B. Front rail.....1
- C. Front rail rectangular tube.....1
- D. Front rail tape scale (not shown).....1

Note:

The assembly contains the corresponding hardware which is not shown in the figure, and can be checked with the exploded view.

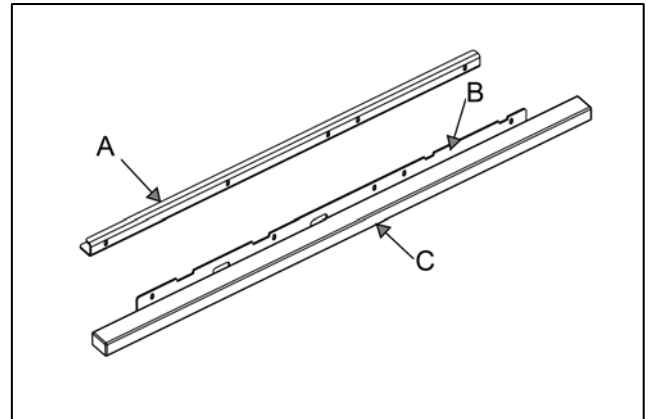

Fig. 5-7

5.4 Installation

Before beginning assembly, take note of the following precautions and suggestions:

FLOOR: Make certain that the floor is a level surface.

WORKING CLEARANCES: If any long material is to be cut, it is necessary to have sufficient room both in front of the machine as well as behind it for material infeed and outfeed.

OUTLET PLACEMENT: Outlets should be located close enough to the machine so that the power cord or extension cord is not in an area where it would cause a tripping hazard.

⚠ WARNING

DO NOT assemble the machine until you are certain that the machine is not plugged in and the power switch is in the OFF position.

DO NOT connect the machine to the power source until you read and understand the entire User Manual.

Pull the switch out of the saw cabinet and remove the shipping brace as Fig. 6-1.

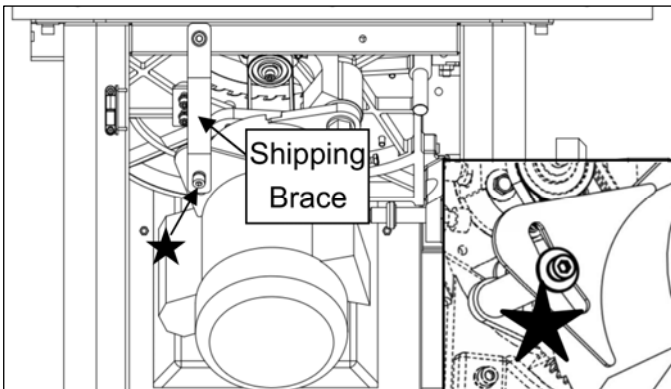

Fig. 6-1

Note: The yellow shipping brace is only used to secure the machine during transportation.

After removing the package and pallet, please take off the yellow shipping brace before installing the machine. And re-install the motor set screw (★).

Check if the belt tension is appropriate, if not, please adjust according the instruction manual.

5.4.1 Remove the pallet

The machine is fixed on the pallet by M8 hex bolts. Before installing, please take off the accessories on the pallet and in the cabinet. Then move the machine out after removing the set bolts under the pallet, as shown in Fig. 6-2. Locate the machine at appropriate place.

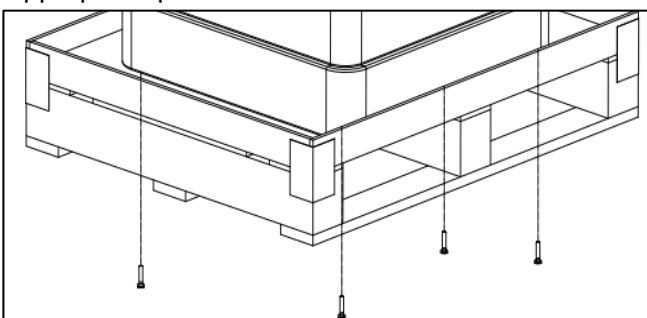

Fig. 6-2

5.4.2 Hand-wheel handle installation

As shown in Fig. 7, install the hand-wheel to the cabinet by using the lock knob, then mount the handle to the hand-wheel.

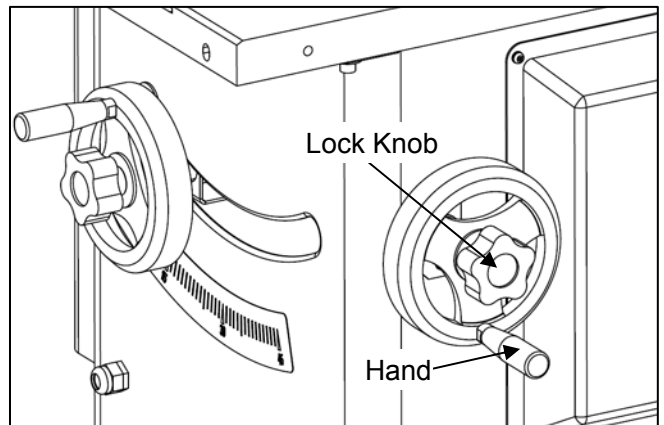

Fig. 7

5.4.3 Extension wings installation (Fig. 8)

The machine is equipped with a cast iron extension wing on the left side of the main table. The mounting bolts of extension wings are pre-mounted in the threaded holes on the main table sides. Install the extension wings as follows:

1. Remove the screws from the sides of the main table;
2. Inspect the extension wings and main table mating surfaces for burrs or foreign materials that may inhibit assembly; the mating edges of the tables must be clean and flat, use a wire brush or sand paper if necessary to clean up the edges;
3. Attach the wings to the main table by using the screws removed in step 1;
4. Use a straightedge to check whether that the main table is coplanar with the extension wing. If not, use a strip of masking tape to shim the extension wing up or down, as directed by the arrow in Fig. 8.

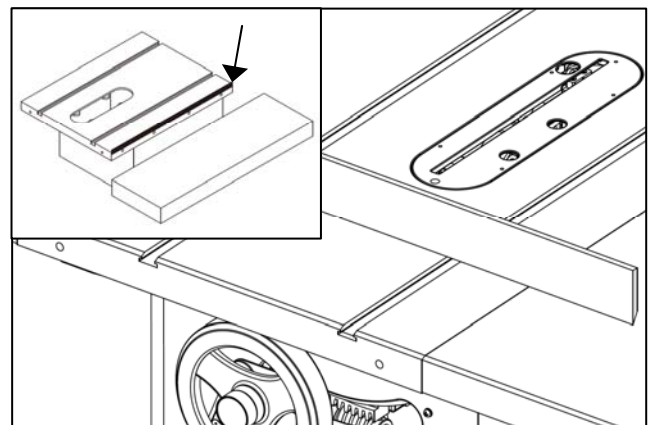

Fig. 8

5.4.4 Install the rail & extension table

1. Install the rail and extension table as breakdown shows.

Before tightening the rear rail, check to make sure the top edge of the rear rail is lower than the T-slot, as shown in Fig. 9.

Ensure that the extension table is coplanar with the main table.

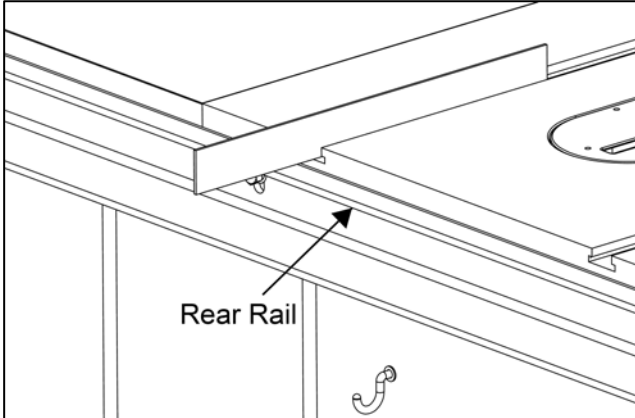

Fig. 9

2. Install the fence on the rail on the right hand side of the blade as shown in Fig. 10.

⚠ NOTICE

Make sure the cam foot contacts the cam on the fence lock handle before you place the fence on the rail, otherwise the fence can not be placed well (Fig. 10).

If you need to use the fence on the left side of the blade, remove the knobs (A), as shown in Fig.10, and move the fence plate and locking bar to the right side of the fence body, secure them on the left side of the fence body.

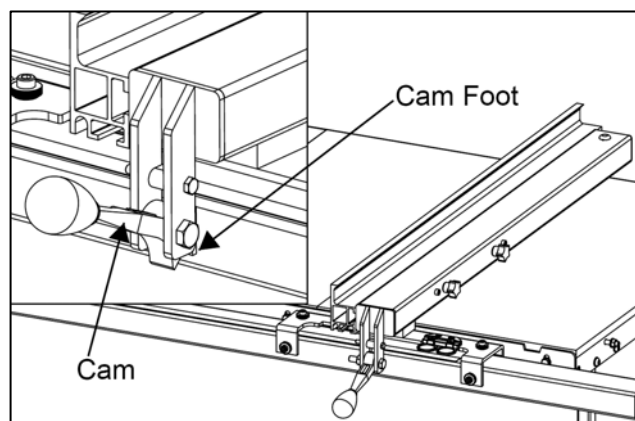

Fig. 10

3. Check the fence parallelism and perpendicularity (Fig.11)

As shown in Fig.11, after securing the fence, ensure that the fence is parallel to the miter slot, which is parallel to blade at any locations. And make sure that the distance $L_1 > L_2$, $L_1 - L_2 < 1/64$ " , which creates a slightly larger opening between the

fence and the blade, at the rear of the blade, to reduce the risk of workpiece binding or burning as it is fed through the cut.

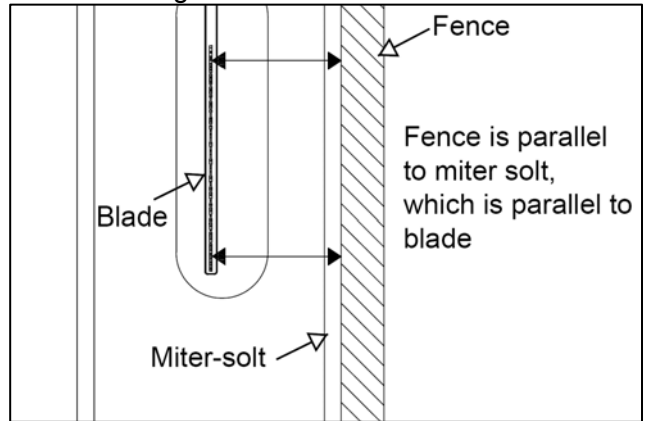

Fig. 11

4. Adjust the parallelism and perpendicularity of the fence (Fig.12)

If the fence or blade is not parallel to the T-slot, or the fence is not perpendicular to the table, you can adjust as following content:

a. Align the the parallelism between the blade and T-slot.

Before aligning perpendicularity or parallelism of the fence, you must align the parallelism between the blade and T-slot, refer to chapter 6.2 Aligning the Table T-slot Parallel with the Blade.

b. Align the the parallelism between the fence and T-slot or blade.

By adjusting the set screw (A), you can adjust the parallelism between fence and blade, also you can adjust the locking strength. By adjusting the bolt marked in a circle as shown in Fig. 12, you can adjust the the perpendicularity between the fence and table. By adjusting the set screw (B), you can adjust the sliding smoothness of the fence.

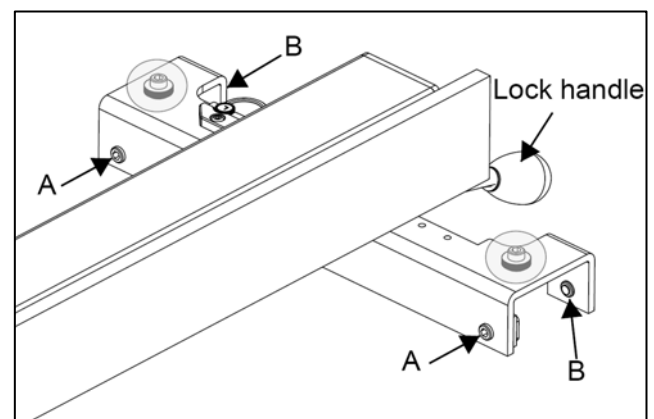

Fig. 12

⚠ NOTICE

By adjusting the support screw (not shown) at the underneath of the fence, you can raise or lower the fence to ensure that the underneath of the fence is parallel to the table.

5.4.5. Post the tape scale use the pointer window (Fig.13)

The machine features a Hi-Low fence with two pointer windows. As shown in Fig.13, two pointer windows can be adjusted individually. The pointer window (A) is for the lower fence while pointer window (B) is for the high fence. You can micro-adjust the position of pointer window by loosening the knob (C) or (D).

Post the Tape Scale

Place the fence as a high fence, slide the fence against the saw blade, and lock it in place; Place the front rail tape scale on the fence tube, make sure it is parallel with the tube, and the "0" end is directly under the red line on the pointer window (B), lightly mark the "0" location on the tube with a pencil, then remove the fence; peel the tape and carefully align the "0" mark on the scale with the pencil mark you made.

Calibrate the Pointer Window

Place the fence as a lower fence, as shown in Fig.13. Slide the fence against the blade, check that if the "0" mark is directly under the red line on the pointer window (A), if any deviation occurs, loosen the knob (C), micro-adjust the pointer window (A), so that the red line on the window is over the "0" mark on the tape, then secure the knob (C).

Place the fence as a high fence. Slide the fence against the blade, check that if the "0" mark is directly under the red line on the pointer window (B), if any deviation occurs, loosen the knob (D), micro-adjust the pointer window (B), so that the red line on the window is over the "0" mark on the tape, then secure the knob (D).

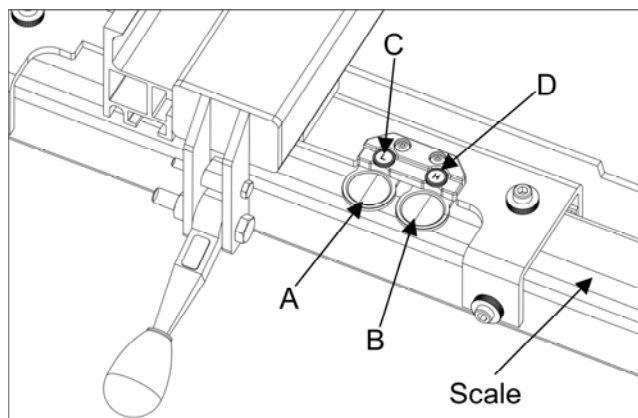

Fig. 13

5.4.6 Install the switch (Fig.14)

The switch differs in different areas:

North America area: Fig.14 (A).

European area: Fig.14 (B).

Asian area: Fig.14(B).

The list above doesn't cover all the countries, the actual object shall prevail.

The switch is mounted on the lower right side of the guide tube by using two sets of bolts which are pre-installed on the guide tube.

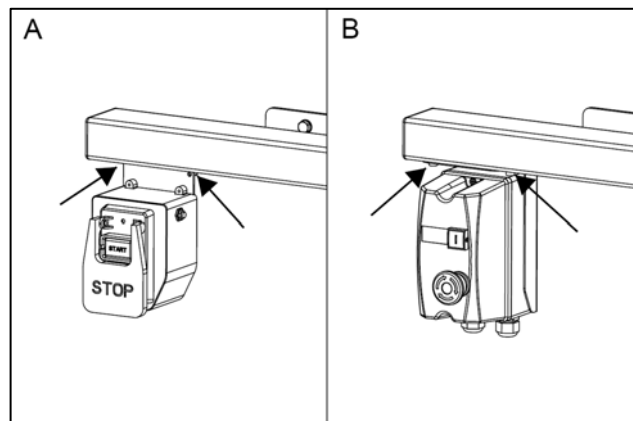

Fig. 14

5.4.7 Install the blade

1. Remove the table insert;
2. Rise the arbor all the way up and set the blade angle at 0°;
3. As shown in **Fig. 15**, press the arbor locking pin by one hand, rotate the arbor until the locking pin engages with the arbor, then remove the arbor nut and flange by using a open end wrench.
4. Slide the saw blade onto the arbor, making sure the teeth face the front of the saw, then install the arbor flange and arbor nut onto the blade and tighten.

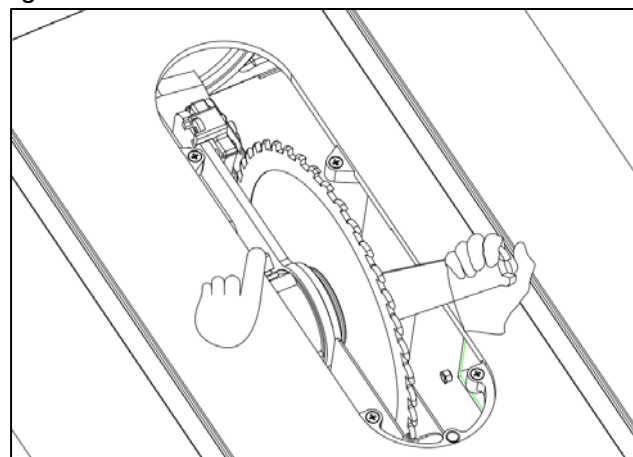

Fig. 15

5.4.8 Install the blade guard

1. Slide the knurled knob out (refer to **Fig. 16**) and rotate it forward so it engages the upper bracket.

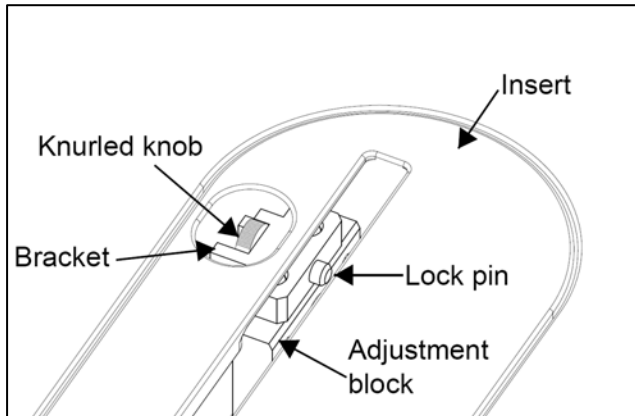

Fig. 16

2. Slide the blade guard spreader all the way down into the block, then rotate the knurled knob so it disengages the bracket and the locking pin engages the hole in the center of the spreader.

3. **Fig.17 (A)** shows the blade guard, meeting the UL62841 standard, is suitable for the North American market. **Fig.17(B)** shows the blade guard meeting the CE standard. For different markets, the machine is equipped with different blade guards, please refer to the chapter “**3. Machine Description**” for detailed information.

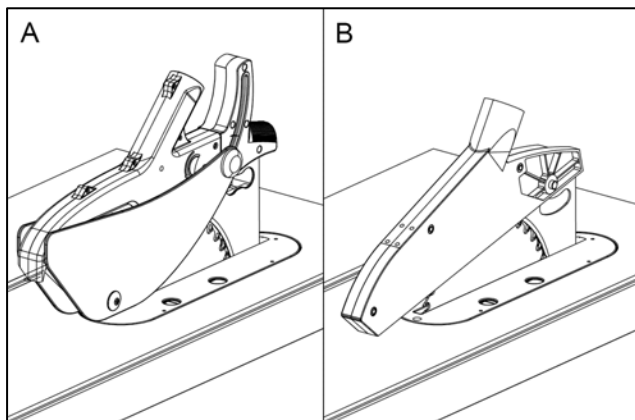

Fig. 17

⚠ WARNING

Check if the saw blade is tightened before operating the machine.
Give the spreader an upward tug to verify if it is locked in place.

5.4.9 Extraction system

⚠ NOTICE

A dust collection device should be used by the customer, the dust extraction equipment must be switched on before commencing machining. Installation of the Dust Outlet (**Fig.18-1** and **18-2**)

As shown in Figure 18-1, secure the dust outlet to the cabinet, and then connect the bellows to the dust outlet, as shown in Figure 18-2.

Note: The mounting hardware of the dust outlet is pre-mounted on the cabinet.

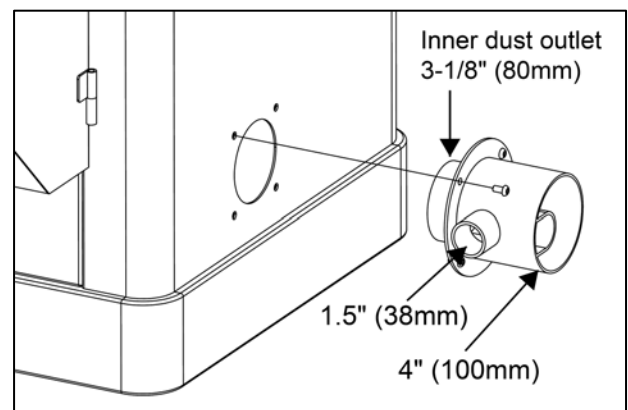

Fig.18-1

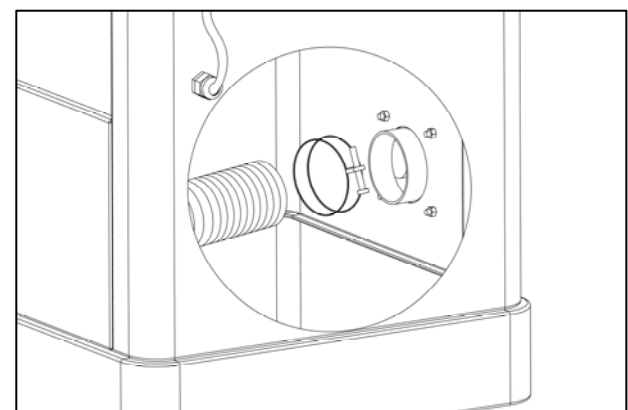

Fig.18-2

Fit the over arm to the rear rail (Fig.18-3):

1. Fit the bracket (A) to the rear rail with screw B.
2. Fit the over arm to the bracket (B) with clip (C). (Total 2 sets of clasps)
3. Connect the pipe (1.5") provided by us to the dust outlet as fig point.

Note: The mounting hardware of the dust outlet is pre-mounted on the cabinet.

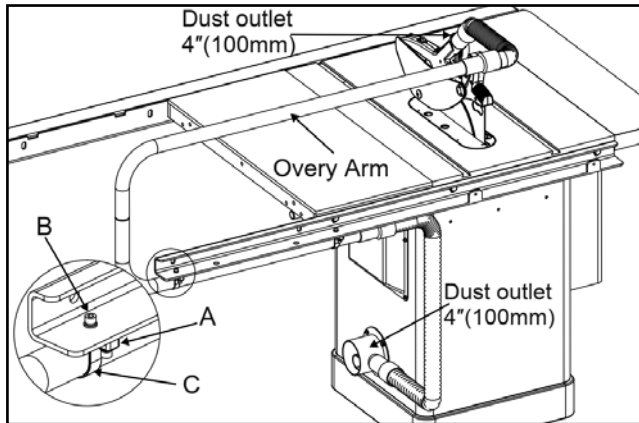

Fig. 18-3

Requirements for the dust collector:

1. Required air flow: 470 CFM (800 m³/h).
2. Ensure pressure drop of each dust collector outlet carrying air current speed: 1100Pa
3. Dry chips: 3937 FPM (20 m/s).
4. Wet chips: 5511 FPM (28 m/s). (water content is equal to 18%)

5.4.10 Motor cover installation

Install the motor cover by inserting the door pins into the hinge sockets on the cabinet as shown in **Fig. 19**.

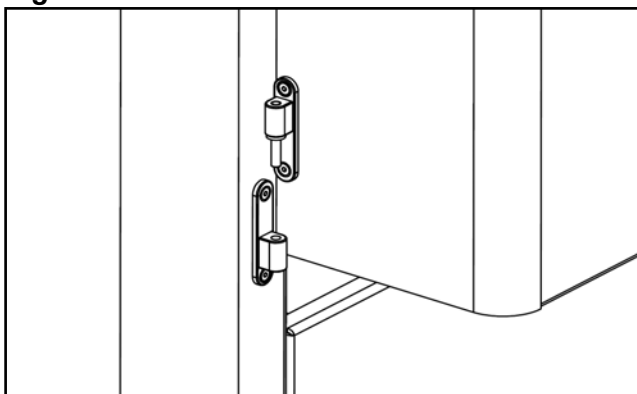

Fig. 19

5.4.11 Miter gauge installation

This machine is equipped with the MG-36 Miter Gauge. This miter gauge is mainly used for guiding workpiece while cross cutting and miter cutting. Please refer to the MG-36 Miter Gauge Manual for detailed installation..

5.4.12 Electrical installation

⚠ WARNING

Wiring should only be done by professional electricians.

Always make sure the machine is properly grounded. All exposed conductive parts should be connected to the protective ground circuit.

An over-voltage protection device should be provided by end user.

The circuit breaker shall be installed to supply electric power to this machine, in order to protect people against electrical shock due to incidental contact.

Check that the voltage and frequency required by the machine, which is shown on the machine's name plate, correspond to the electric power supply voltage and frequency.

Ensure IP54 protection class for the incoming cable when the finished installation is in place.

For single-phase motor, the equipment is equipped with a plug.

For three-phase motor, only power cables are reserved.

Checking:

After finishing wiring in place, at minimum, check the following items:

1. Check the direction of motor and change the wiring if necessary.
2. Check the components for defects, such as damaged cable or plug.
3. Check the function of the "OFF" button.

ELECTRICAL DIAGRAM

2 HP, 60 Hz, 115/230 V, 1 PH

115 V Wiring Diagram

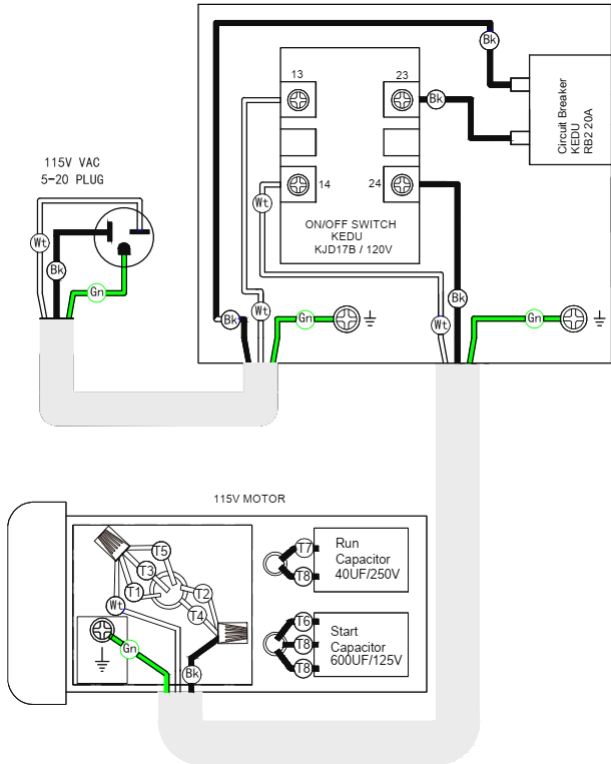

230 V Wiring Diagram

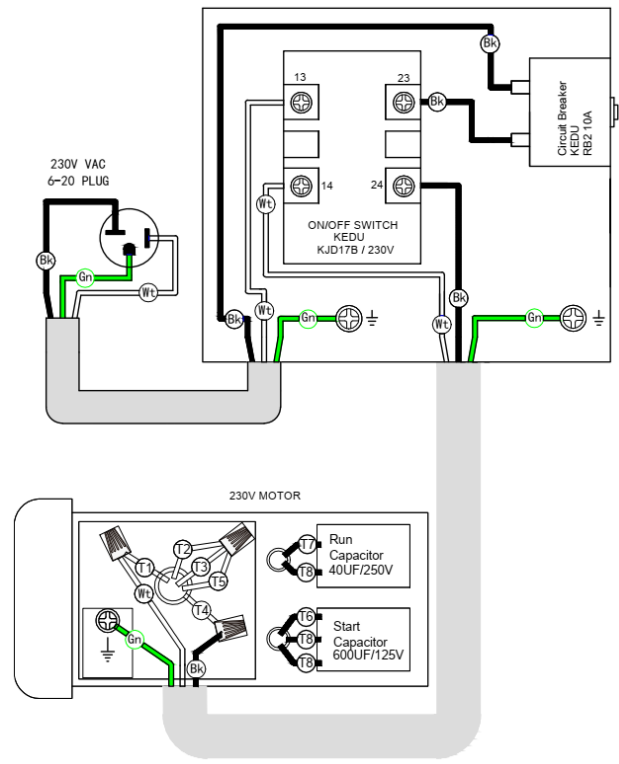

Remark:

1. The colour of single core may differ with the illustration above in different areas.
2. Single-phase power supply range: 110-120V or 200-240 V.
The machine is pre-wired with the voltage of 115V.
3. Meeting the standard of UL62841, this electrical diagram is designed for North-American areas.
4. This machine is equipped with the 5-20P plug which is suitable for North America area.

1.65 kW, 50 Hz, 230 V, 1 PH

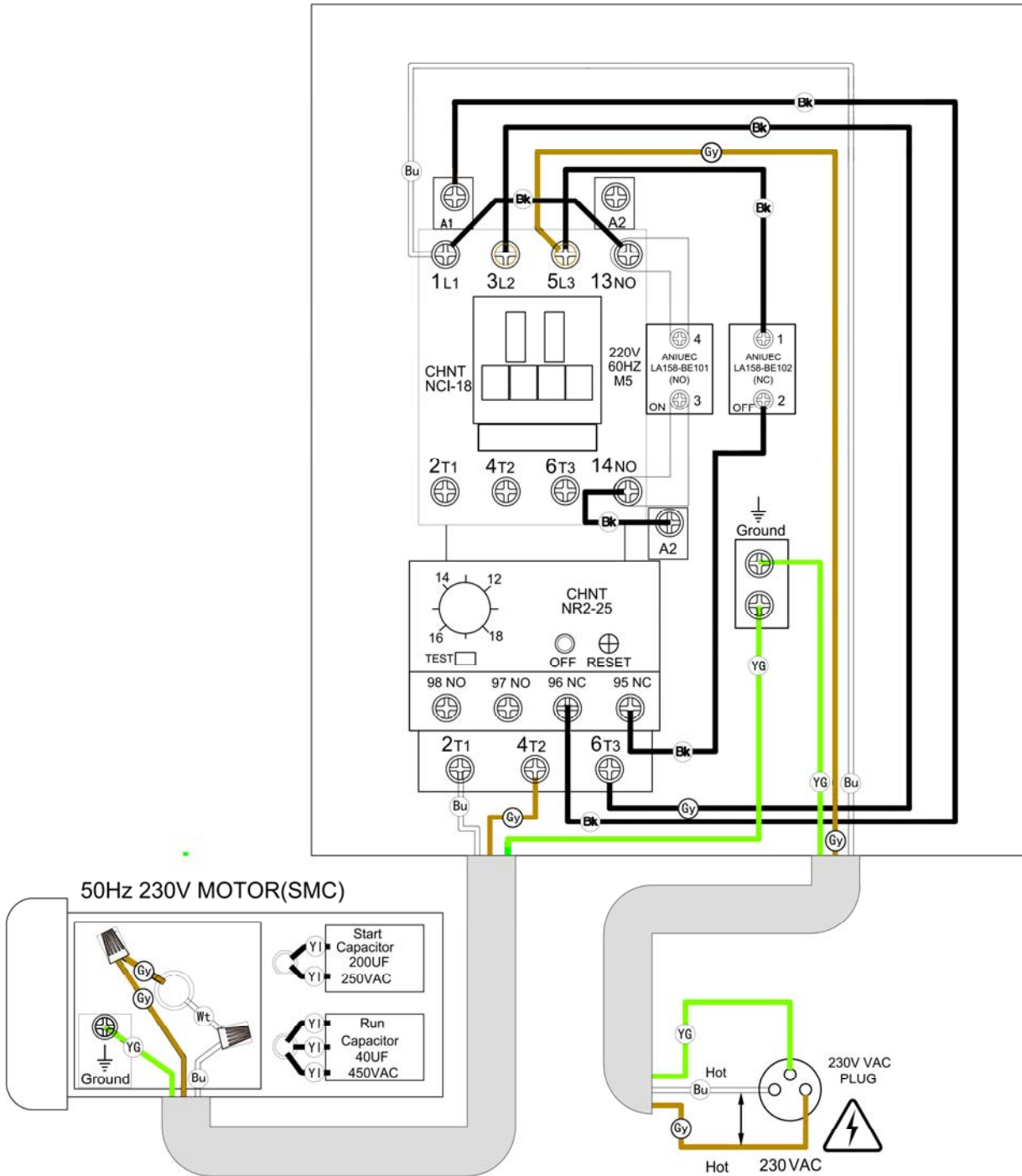

Remark:

1. The colour of single core may differ with the illustration above in different areas.
2. Single-phase power supply range: 200-240V.
3. Meeting the CE standard, this electrical diagram is designed for European and Asian areas.
4. This machine is equipped with the industrial plug of European standard. If there's no matched outlet, you can change the plug to a new one of 16A which meets the local power regulation.

Rewiring for 230V Power

(Note: This chapter is only available for the table saw with dual voltages.)

WARNING

The power must be disconnected before any wiring operations!

This table saw can be used for 115V or 230V power. It comes from the factory pre-wired for 115V, so if you want to use it for 230V, you need to take off the switch box, replace the circuit breaker, switch panel and power cable, rewire the parts and adjust the wiring of the motor. The detailed steps are as followings:

NOTICE

The new circuit breaker and switch panel used for 230V are provided together with the table saw, but the power cable with plug (6-20P) for 230V needs to be purchased separately.

1. As shown in **Fig. 20**, unscrew the screws (A) and loosen the strain reliefs (B), then take off the switch box.

NOTICE

Since the terminals' wiring positions in the switch box are same for 115V and 230V, we suggest you take photos of the terminals' wiring positions as a reference for the following rewiring. Also if you encounter any wiring problems, please refer to **Fig. 21** or the Electrical Diagram.

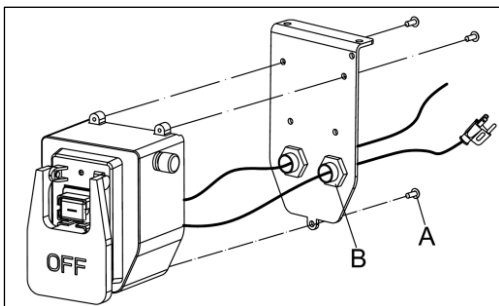

Fig. 20

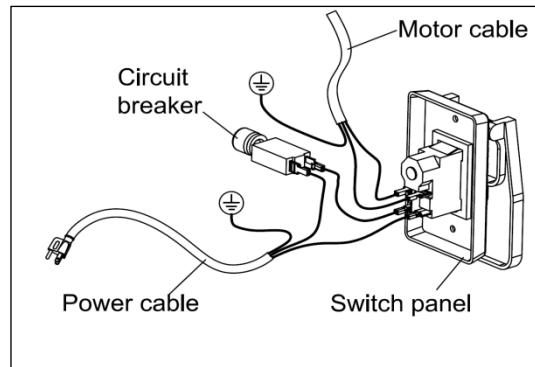

Fig. 21

2. Disconnect all the terminals' wiring inside the switch box and the earth terminal's wiring of the power cable.

a. Replace the circuit breaker (by loosening the protection cap) with the new one that is used for 230V, then tighten the protection cap.

b. As shown in **Fig. 22**, unscrew the screws (C) and replace the switch panel with the new one that is used for 230V, then tighten the screws.

c. Replace the whole power cable with the new one that has the plug of 6-20P and tighten the strain reliefs.

d. Then referring to **Fig. 21** or the Electrical Diagram or the photos you've take in Step 1, rewire all the cables to the terminals correctly. Mount the switch box back by tightening the screws.

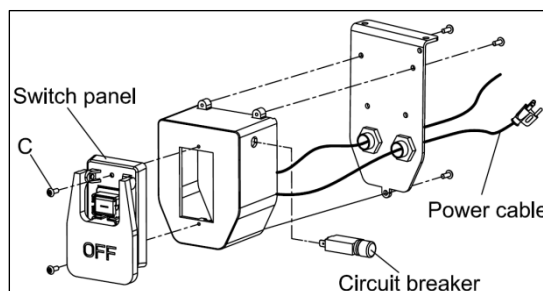

Fig. 22

3. Adjust the wiring of the motor according to the Electrical Diagram.

6. Adjustment

NOTICE

Before operation, Please make adjustments as followings:

6.1 Adjusting the Rip Fence

Before using the rip fence, the parallelism and perpendicularity must be aligned correctly. Please refer to chapter 5.4.4 Install the rail & fence.

6.2 Aligning the Table T-slot Parallel with the Blade

1. The table T-slot must be aligned parallel with the blade. Using a combination square measure the distance from the back edge of the blade to the table T-slot. Pivot blade forward 180° and re-measure the distance using the exact same point on the blade. The difference between both measurements must be less than 0.2mm. Refer to **Fig. 23**.

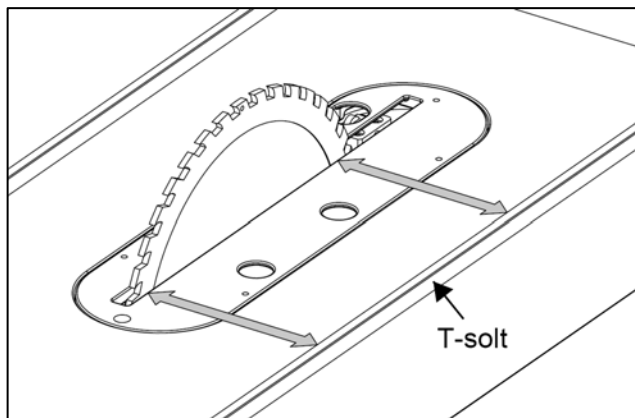

Fig. 23

2. If an adjustment is necessary, loosen the two M5-8x8 set screws (A) and four M10-1.75x25 cap screws (B) identified in **Fig. 24** which mount the table to the cabinet. Make the needed adjustment until both measurements are equal or less than 0.2 mm. then re-tighten all the screws.

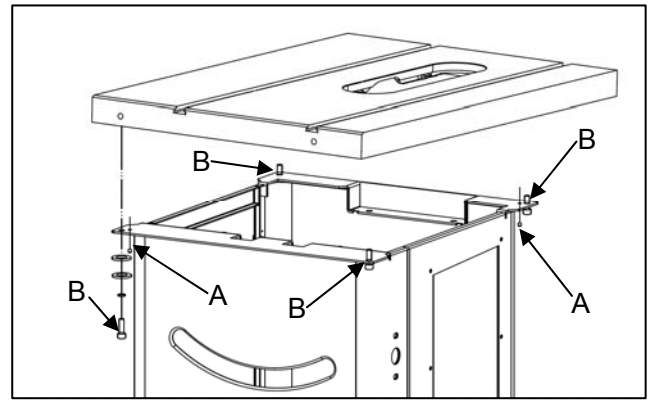

Fig. 24

6.3 Adjusting the 45° and 90° Positive Stops

The tilt mechanism has adjustable stops for 45° and 90°. The machine comes factory-set, but should any positioning deviation of the blade occur, you can re-adjust the stops. Refer to **Fig. 25**.

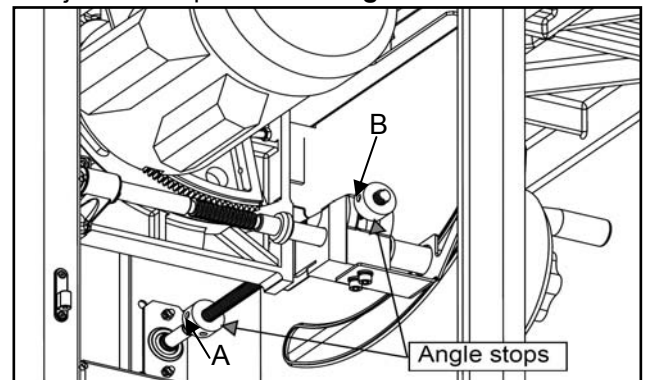

Fig. 25

To adjust the 90° Positive Stop, open the motor cover on the left side of the machine. Then loosen the set screw (B) and rotate the 90° Positive Stop to desired position. Re-tighten the set screw (B) after adjustment.

To adjust the 45° Positive Stop, loosen the screws of the repair panel on the right side of the machine and take off the repair panel. Then loosen the set screw (A) and rotate the 45° Positive Stop to desired position. Re-tighten the set screw (A) after adjustment.

6.4 Aligning the Riving Knife with Blade

The riving knife must be aligned with the blade. If not properly aligned, the riving knife will force the workpiece sideways during the cut, increasing the risk of kickback. Place a straightedge against the blade and the riving knife and check if the riving knife is in the "alignment zone," refer to **Fig. 26**.

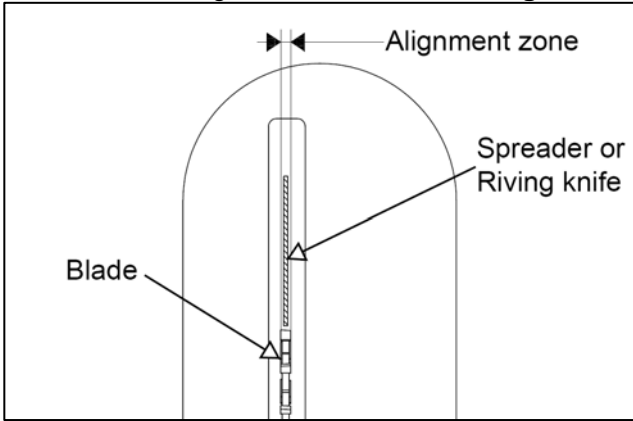

Fig. 26

If it is not aligned properly, please adjust as following (**Fig. 27**):

1. Disconnect the saw from the power source.
2. Remove the table insert.
3. Loosen the upper and lower cap screws (B), then adjust the set screws (A) in or out until the alignment is perfectly parallel, then tighten the screws (A) and (B).
4. Re-install the table insert.

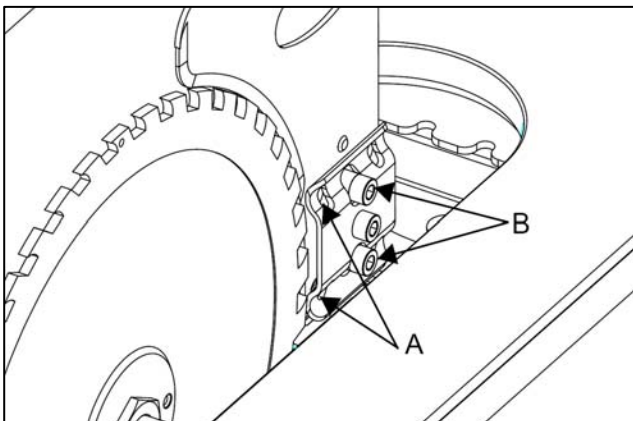

Fig. 27

⚠ NOTICE

1. Riving knives shall be manufactured from steel with an ultimate tensile strength of 580 N/mm² or of a comparable material, have flat sides (within 0.1 mm per 100 mm) and shall have a thickness less than the width of a cut (kerf) and at least 0.2mm

greater than the saw blade plate. As shown in **Fig. 28**.

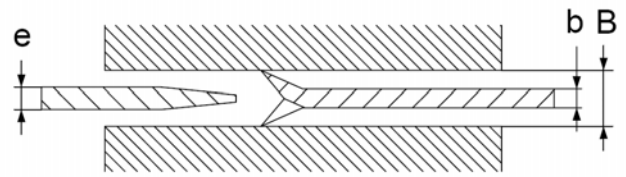

Fig. 28

Key:

- e** riving knife thickness
- b** saw blade base
- B** kerf (width of saw blade cut)

2. The distance of the riving knife from the gear rim must be between 3 mm and 8 mm measured radially through the center of the saw spindle. As shown in **Fig. 29**.

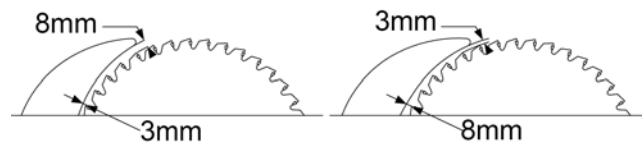

Fig. 29

3. The highest point of the riving knife must be set beneath the topmost teeth

7. Operations

7.1 Electrical Operation

Two types of the switches are alternative for your machine, the actual object shall prevail.

Refer to *Fig. 30* & *Fig.31*

“**ON**” Button: Start the machine.

“**OFF**” Button: Stop the machine.

Hole for Safety Lock: While not using the machine, insert the safety pin to prevent accidental start up.

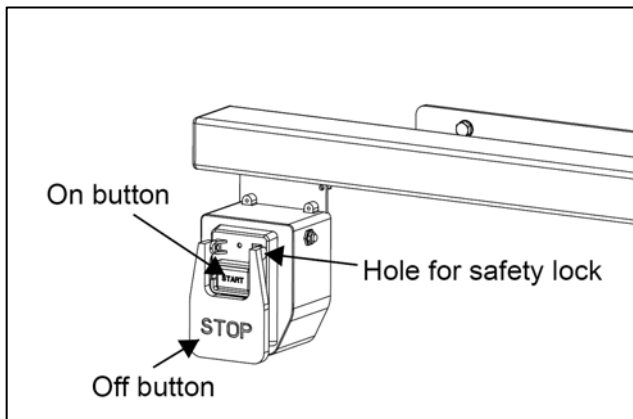

Fig. 30

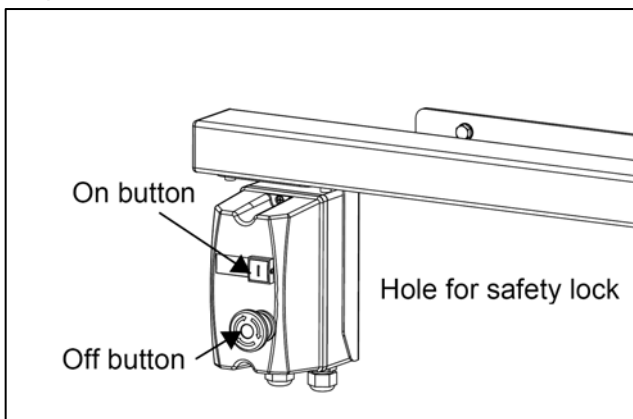

Fig. 31

7.2 Blade Elevation and Tilting Adjustment

To adjust the blade elevation : Loosen the lock knob (C) as shown in *Fig. 32* and turn the elevation hand wheel (D). When the desired height is obtained, re-tighten the knob (C). The blade should be raised 1/8” to 1/4” above the top surface of the material being cut.

To adjust the blade tilting : Loosen the lock knob (B) and turn the hand wheel (A). When the desired angle is obtained, re-tighten the knob (B).

Refer to *Fig. 32*.

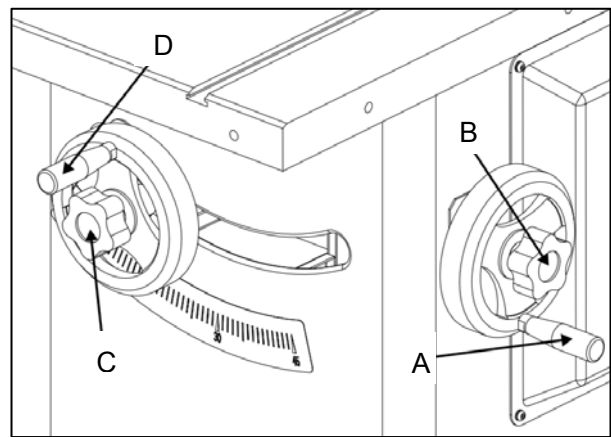

Fig. 32

7.3 Crosscutting

"Crosscutting" means cutting across the grain of a natural wood workpiece. In other man-made materials, such as MDF or plywood, crosscutting means cutting across the width of the workpiece. Crosscutting requires the use of the miter gauge to position and guide the work. Place the work against the miter gauge and advance both the miter gauge and work toward the saw blade.

Start the cut slowly and hold the work firmly against the miter gauge and the table. One of the rules in running a saw is that you never hang onto or touch a free piece of work. Hold the supported piece, not the free piece that is cut off. The feed in crosscutting continues until the work is cut in two, then the miter gauge and work are pulled back to the starting point. Before pulling the work back, it is good practice to give the work a little sideways shift to move the work slightly away from the saw blade.

Never pick up any short length of free work from the table while the saw is running. A smart operator never touches a cut-off piece unless it is at least a foot long. Never use the fence as a cut-off gauge when crosscutting. Never use the miter gauge in combination with the rip fence.

7.4 Ripping

"Ripping" means cutting with the grain of a natural wood workpiece. In other man-made materials such as MDF or plywood, ripping simply means cutting lengthwise.

The rip fence is used to position and guide the work. One edge of the work rides against the rip fence while the flat side of the board rests on the table. Since the work is pushed along the fence, it must have a straight edge and make solid contact with the table. The saw guard must be used. The guard has a splitter to prevent the saw kerf from closing.

Start the motor and advance the work holding it down and against the fence. Never, stand in the line of the saw cut when ripping. Hold the work with both hands and push it along the fence and into the saw blade..

Alternately, the feed can continue to the end of the table, after which the work is lifted and brought back along the outside edge of the fence. The waste stock remains on the table and is not touched with the hands until the saw is stopped unless it is a large piece allowing safe removal.

8. Maintenance

This table saw has TEFC motor and sealed lubricated bearings, which requires very little maintenance other than minor lubrication and cleaning. Please do the maintenance as following contents.

LUBRICATION

Clean off the wood chips on the worm gears and trunnions and apply the grease to keep them lubricated.

Lubricate once a month.

CLEANING

Clean the wood chips on the table surface and in the cabinet.

Clean once a day.

CHANGING BELT

WARNING

Make sure the power cord is disconnected from the power source!

1. Lower the blade completely, then open the motor cover (right side), remove the repair panel (left side), refer to *Fig. 33*.
2. Loosen the hex bolt that secures the motor and raise the motor fully to remove tension on the V-Ribbed belt. Roll the V-Ribbed belt off.
3. Raise the motor and install a new V-Ribbed belt onto the pulleys, lower the motor to tension the V-Ribbed belt, then tighten the hex bolt.
4. Close the motor cover and repair panel.

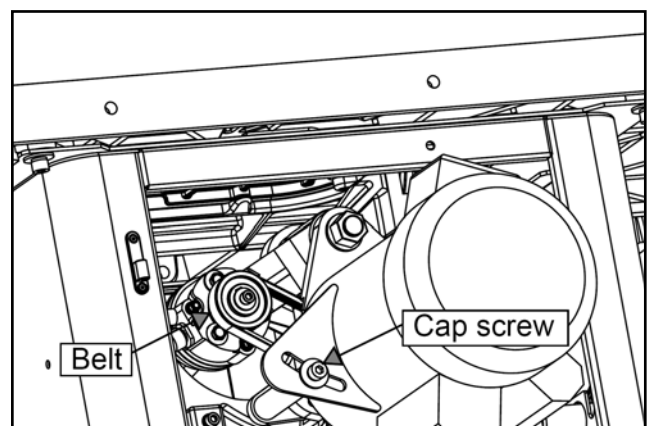

Fig. 33

9. Trouble Shooting

PROBLEM	SOLUTION
<p>SAW WILL NOT START</p> <ol style="list-style-type: none"> 1. Saw not plugged in. 2. Fuse blown or circuit breaker tripped. 3. Cord damaged. 	<ol style="list-style-type: none"> 1. Plug in saw. 2. Replace fuse or reset circuit breaker. 3. Have cord replaced by a certified electrician.
<p>OVERLOAD KICKS OUT FREQUENTLY</p> <ol style="list-style-type: none"> 1. Extension cord too long or gauge size too small. 2. Feeding stock too fast. 3. Blade in poor condition (dull, warped, gummed). 4. Blade binding due to misaligned rip fence. 5. Blade binding due to warped wood. 6. Low house current. 	<ol style="list-style-type: none"> 1. Replace with adequate size cord 2. Feed stock more slowly. 3. Clean or replace blade. 4. Check and adjust the rip fence. Refer to rip fence instructions. 5. Select another piece of wood. 6. Contact your electrical company.
<p>DOES NOT MAKE ACCURATE 45 AND 90 RIP CUTS</p> <ol style="list-style-type: none"> 1. Positive stop(s) not adjusted properly. 2. Tilt angle pointer not set properly. 	<ol style="list-style-type: none"> 1. Check blade with square and adjust positive stop. 2. Check blade with square and adjust pointer to zero.
<p>MATERIAL PINCHES BLADE WHEN RIPPING</p> <ol style="list-style-type: none"> 1. Rip fence not aligned with blade. 2. Warped wood. 	<ol style="list-style-type: none"> 1. Check and adjust rip fence. 2. Select another piece of wood.
<p>MATERIAL BINDS ON SPLITTER</p> <ol style="list-style-type: none"> 1. Splitter not aligned correctly with blade. 	<ol style="list-style-type: none"> 1. Check and align splitter with blade.
<p>SAW MAKES UNSATISFACTORY CUTS</p> <ol style="list-style-type: none"> 1. Dull blade. 2. Blade mounted backwards. 3. Gum or pitch on blade. 4. Incorrect blade for work being done. 5. Gum or pitch on table causing erratic feed. 	<ol style="list-style-type: none"> 1. Replace blade. 2. Turn blade around. 3. Remove blade and clean with turpentine and steel wool. 4. Change the blade. 5. Clean the table with turpentine and steel wool.
<p>BLADE DOES NOT COME UP TO SPEED</p> <ol style="list-style-type: none"> 1. Extension cord too light or too long. 2. Low house current. 3. Motor not wired for correct voltage. 	<ol style="list-style-type: none"> 1. Replace with adequate size extension cord. 2. Contact your electric company. 3. Refer to motor and /or nameplate.
<p>MACHINE VIBRATES EXCESSIVELY</p> <ol style="list-style-type: none"> 1. Table not mounted securely to cabinet stand. 2. Stand is on uneven floor. 3. Damaged saw blade. 4. Bad V-Ribbed belt. 5. V-Ribbed belt is not tensioned properly. 6. Improper motor mounting. 7. Loose hardware. 	<ol style="list-style-type: none"> 1. Tighten all mounting hardware. 2. Reposition on flat level surface. 3. Replace blade. 4. Replace V-Ribbed belt. 5. Adjust V-Ribbed belt tension. 6. Check and adjust motor mounting. 7. Tighten all nuts, bolts and set screws.

10. Exploded View and Parts List

Table Saw Body Exploded View

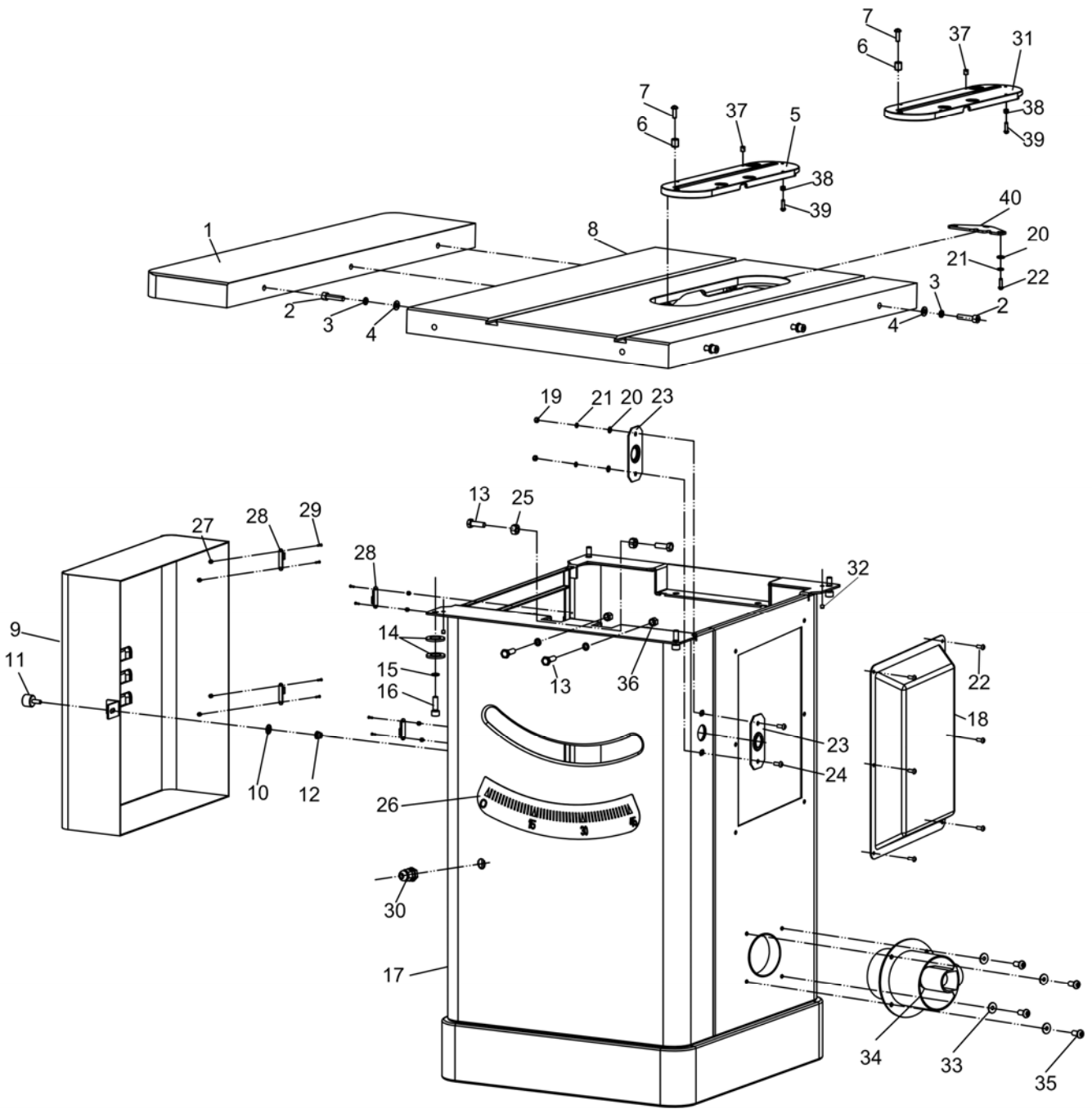

Body Assembly Parts List

REF#	DESCRIPTION	REF#	DESCRIPTION
1	Left extension table	21	Lock washer 5
2	Cap screw M8-1.25 x 35	22	Button HD screw M5-.8 x 12
3	Lock washer 8	23	Lead screw bracket
4	Flat washer 8	24	Button HD screw M5-.8 x 16
5	Table insert (standard)	25	Lock nut M8-1.25
6	Set screw	26	Tilt scale
7	Button HD screw M5-.8 x 16	27	Lock nut M3-.5
8	Main table	28	Upper and lower hinge
9	Motor cover	29	Flat HD screw M3-.5 x 12
10	Tooth washer 6	30	Strain relief M18-1.5
11	Knob M6-1	31	Table insert (dado)
12	Riveted nut 6-1x15	32	Set screw M5-.8 x 8
13	Hex bolt M8-1.25 x 25	33	Flat washer 6
14	Flat washer 10	34	Dust port 4" x 1-1/2"
15	Lock washer 10	35	Button HD screw M6-1 x 12
16	Cap screw M10-1.75 x 25	36	Lock nut M8-1.25
17	Cabinet	37	set screw M5-.8 x 12
18	Access cover	38	Lock nut M5-.8
19	Hex nut M5-.8	39	Button HD screw M5-0.8 x 20
20	Flat washer 5	40	Limit insert

Trunnion Assembly Exploded View

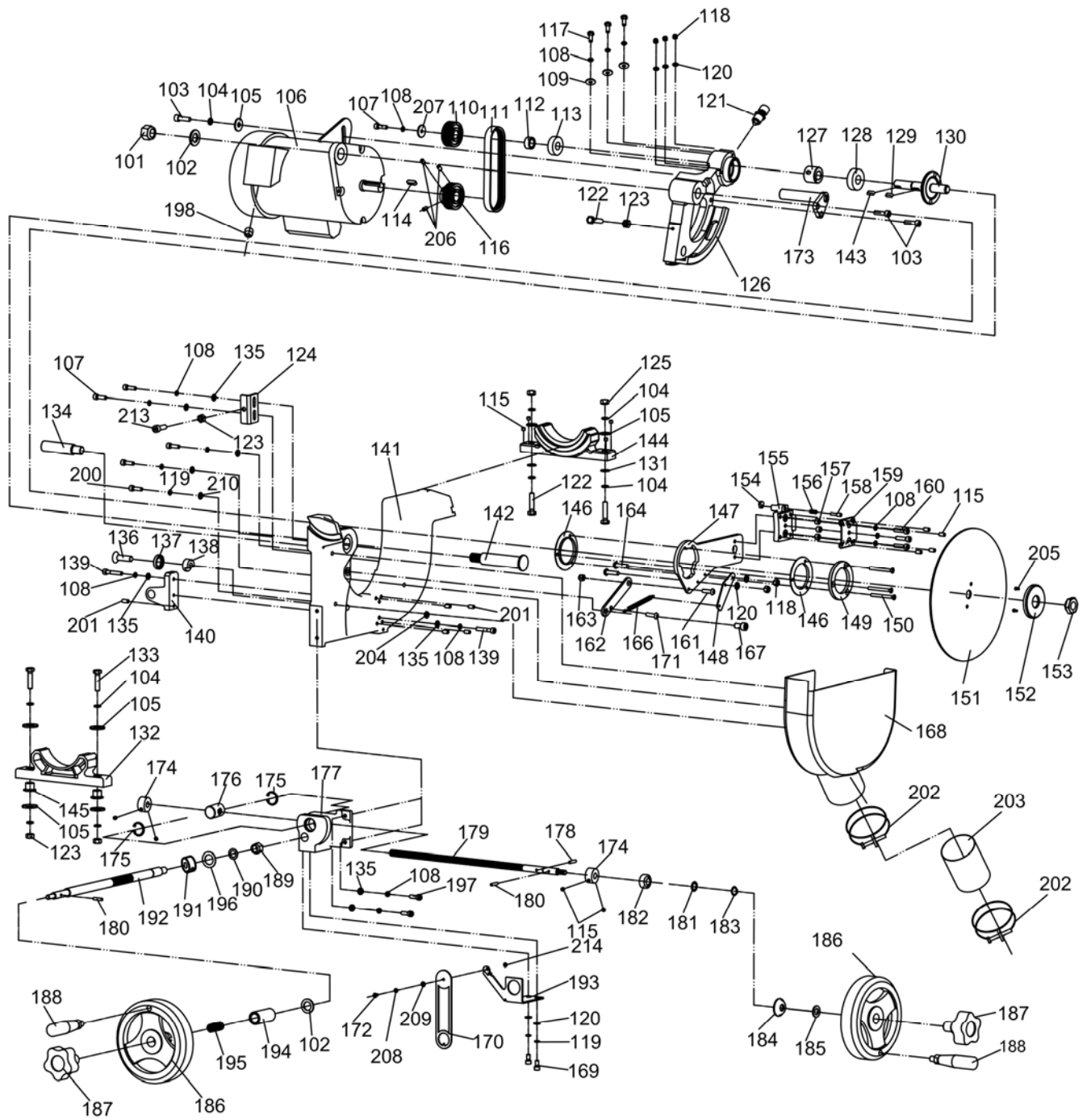

Trunnion Assembly Parts List

REF#	DESCRIPTION	REF#	DESCRIPTION	REF#	DESCRIPTION
101	Lock nut M16-2	138	Spacer (Nylon)	175	Int retaining ring 24
102	Flat washer 16	139	Cap screw M6-1 x 35	176	Tilt leadscrew nut
103	Cap screw M8-1.25 x 20	140	Shaft bracket	177	Tilt leadscrew base
104	Lock washer 8	141	Main trunnion	178	Roll pin 4 x 16
105	Large washer 8	142	Motor shaft	179	Tilt leadscrew
106	Motor	143	Key 5 x 6 x 16	180	Roll pin 4 x 20
107	Cap screw M6-1 X 16	144	Rear trunnion	181	Flat washer 12
108	Lock washer 6	145	Adjustment screw	182	Bearing
109	Large washer 6	146	Nylon gasket	183	Ext retaining ring 12
110	Arbor pulley	147	Spreader bracket	184	Beveled bushing
111	Poly V-belt 150PJ6	148	Spring bracket	185	Flat washer 12
112	Bushing	149	Flange ring	186	Handwheel
113	Ball bearing 6202-2RS	150	Flat HD screw M5-.8 x 50	187	Lock knob M8-1.25
114	Motor key	151	Sae blade 10" x 40T	188	Handle 90L, M10-1.5 x 12
115	Set screw M6-1 X 8	152	Arbor flange 7.2mm thick	189	Lock nut M12-1.75
116	Motor pulley	153	Arbor nut	190	Flat washer 12
117	Hex bolt M6-1 X 16	154	Knurled knob	191	Collar
118	Lock nut M5-.8	155	Spreader adjustment block	192	Elevation shaft
119	Lock washer 5	156	Compression spring	193	Pointer base
120	Flat washer 5	157	Spacer	194	Handwheel bushing
121	Arbor lock	158	Lock pin 6 x 26	195	Compression spring
122	Hex bolt M8-1.25 X 40	159	Spreader clamping plate	196	Elevation shaft spacer
123	Hex nut M8-1.25	160	Cap screw M6-1x25	197	Cap screw M6-1 x 20
124	Height limit block	161	Button HD screw M6-1 x 20	198	Strain relief
125	Lock nut M8-1.25	162	Connecting plate	199	Cap screw M5-.8 x 30
126	Motor mount	163	Lock nut M6-1	200	Cap screw M5-.8 x 20
127	Arbor bushing	164	Button HD screw M5-.8 x 16	201	Set screw M6-1 x 20
128	Ball bearing 6203-2RS	165	Hex nut M8-1.25	202	Hose clamp 3-1/4"
129	Key 5 x 5 x 14	166	Extension spring	203	Clear hose 30" x 3"
130	Arbor	167	Shoulder screw	204	Thin nut M10-1.5
131	Flat washer 8	168	Dust collector case	205	Cap screw M4 x 6
132	Roint trunnion	169	Cap screw M5-.8 x 12	206	Set screw M6-1 X 8
133	Hex bolt M8-1.25 X 45	170	Pointer	207	Extra large washer 6
134	Limit block	171	Button HD screw M5-.8 x 12	208	Lock washer 4
135	Flat washer 6	172	Button HD screw M4-.7 x 10	209	Flat washer 4
136	Flat HD screw M10-1.5 x 40	173	Motor locationshaft	210	Large washer 5
137	Spacer	174	Stop collar	213	Cap screw M8-1.25 x 25
				214	Nut M4-.7

Blade Guard Exploded View

GLIDER Saw Blade Guard (UL62841)

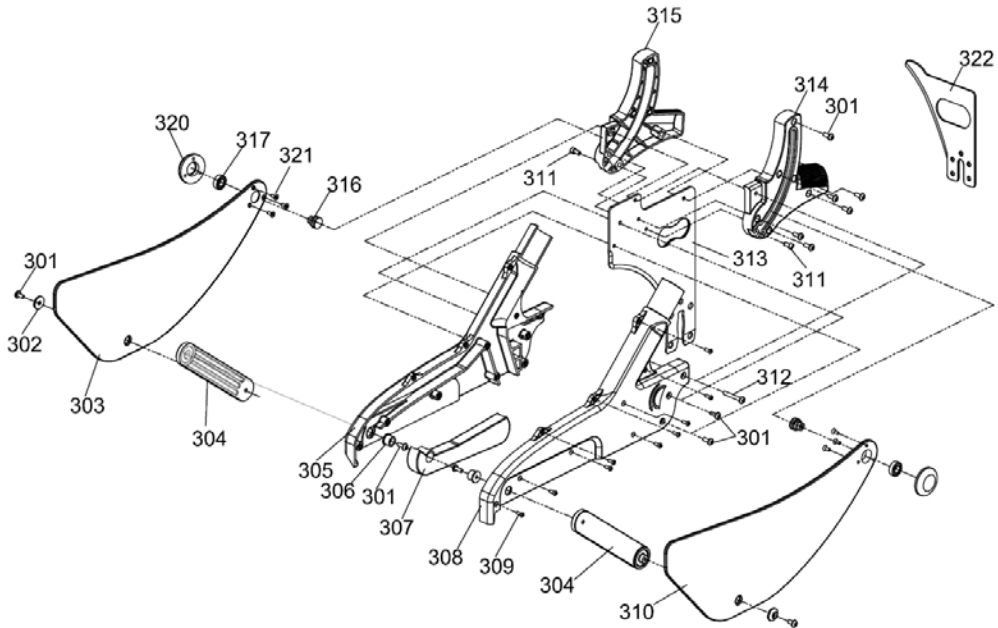

REF	DESCRIPTION	REF	DESCRIPTION
301	Pan HD screw M4-0.7x12 Nickel	312	Pan HD screw M4-0.7x28 Nickel
302	Plastic spacer	313	Spreader
303	Left guard	314	Right guide block
304	Guard support	315	Left guide block
305	Left cover	316	Roller
306	Plastic liner	317	Bearing 689ZZ
307	Front guard	318	/
308	Right cover	319	/
309	Cap screw M3-0.5x8 Nickel	320	Cover clamp
310	Right guard	321	Flat HD screw M3-0.5x8
311	Cap screw M4-0.7x8	322	Riving knife

CE Version Saw Blade Guard

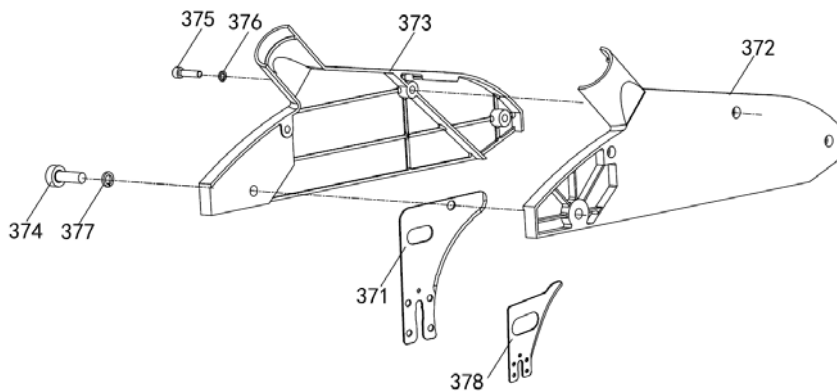

REF	DESCRIPTION	REF	DESCRIPTION
371	Spreader	375	Pan HD screw M6-1x25
372	Left guard	376	Lock washer 6
373	Right guard	377	Lock washer 10
374	Cap screw M10-1.5x30	378	Riving knife

Fence Exploded View

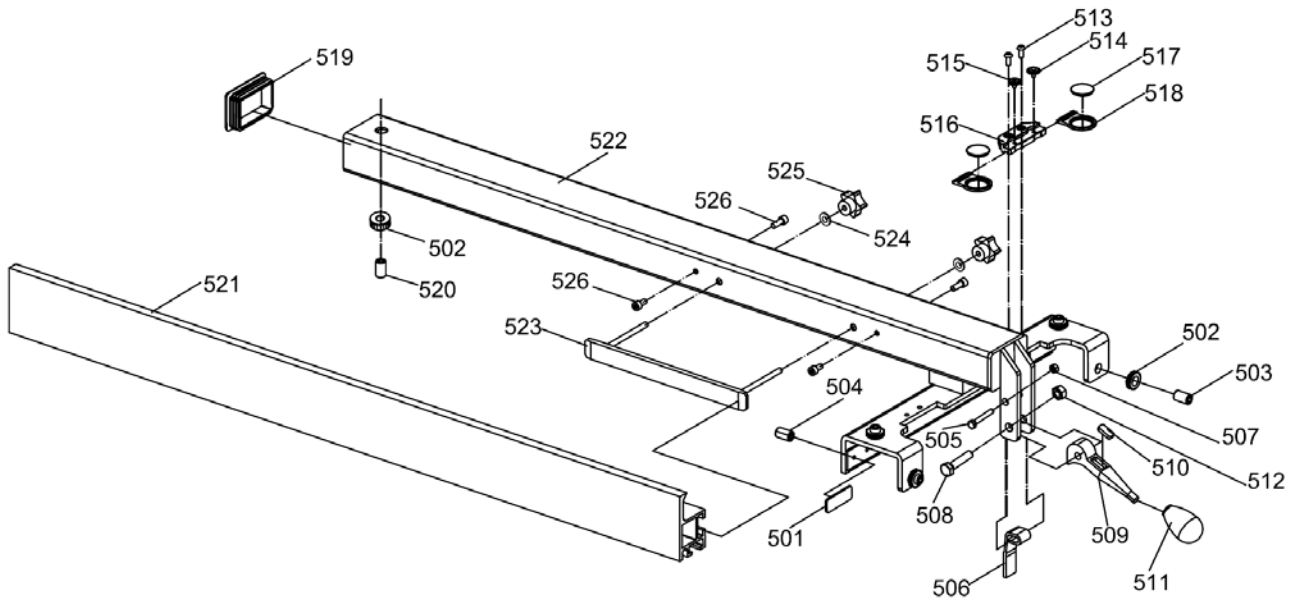

REF	DESCRIPTION
501	Glide pad
502	Special locking nut M12-1.75
503	Set screw M12-1.75x16
504	Set screw M12-1.75x10
505	Hex bolt M6-1x40
506	Cam foot
507	Lock nut M6-1
508	Hex bolt M10-1.5x45
509	Cam
510	Magnet
511	Fence lock knob M10-1.5
512	Lock nut M10-1.5
513	Button HD screw M5-.8x10

REF	DESCRIPTION
514	Lock knob for High Fence
515	Lock knob for Low Fence
516	Window fixing block
517	Window
518	Window bracket
519	Fence end cap
520	Set screw M12-1.75x30
521	Fence
522	Fence base
523	T-bolt M6-1
524	Plastic washer 6
525	Knob M6-1
526	Cap screw M6-1x12

36" Rail & Extension Table Exploded View

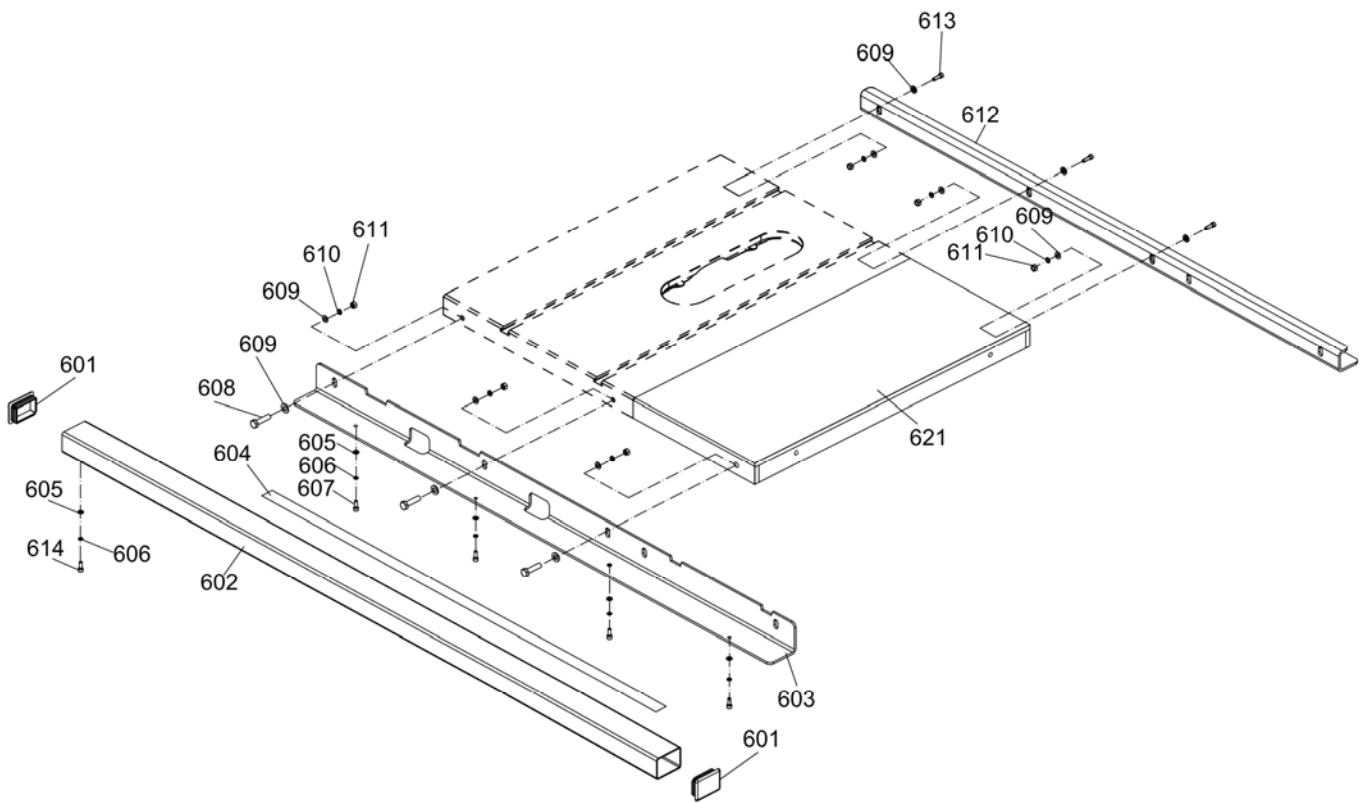

36" Rail & Extension Table Parts List

REF#	DESCRIPTION	REF#	DESCRIPTION
601	Tube cover	609	Flat washer 8
602	Tube	610	Lock washer 8
603	Front rail	611	Hex nut M8-1.25
604	Scale	612	Rear rail
605	Flat washer 6	613	Cap screw M8-1.25 x 35
606	Lock washer 6	614	Cap screw M6-1 x 16
607	Cap screw M6-1x16	615	/
608	Hex bolt M8-1.25x35	621	Extension platen

Switch Exploded View

Switch (UL62841):

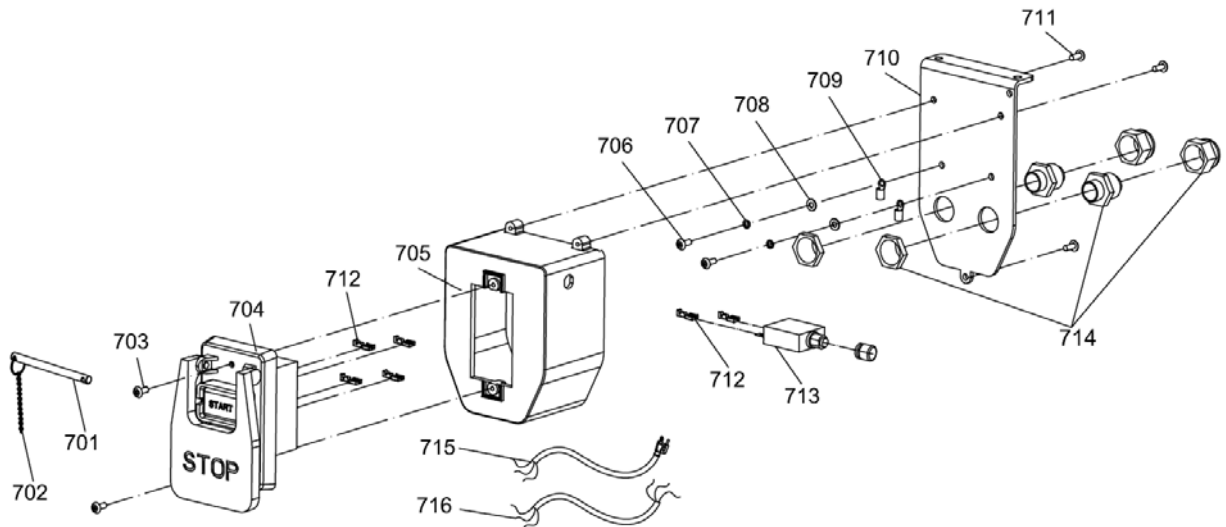

REF	DESCRIPTION	REF	DESCRIPTION
701	Safety pin	709	O type terminal
702	Chain	710	Switch bracket
703	Tapping screw M3.5x19	711	Tapping screw M3.5x10
704	Switch	712	Spring terminal
705	Switch box	713	Overload protection switch
706	Pan HD screw M4-0.7x8	714	Strain relief PG13.5
707	Lock washer 4	715	Cable for power supply
708	Flat washer 4	716	Cable for motor

Note: The Power switch and circuit breaker used for voltage conversion (115V/230V) are provided with the machine.

Switch (CE):

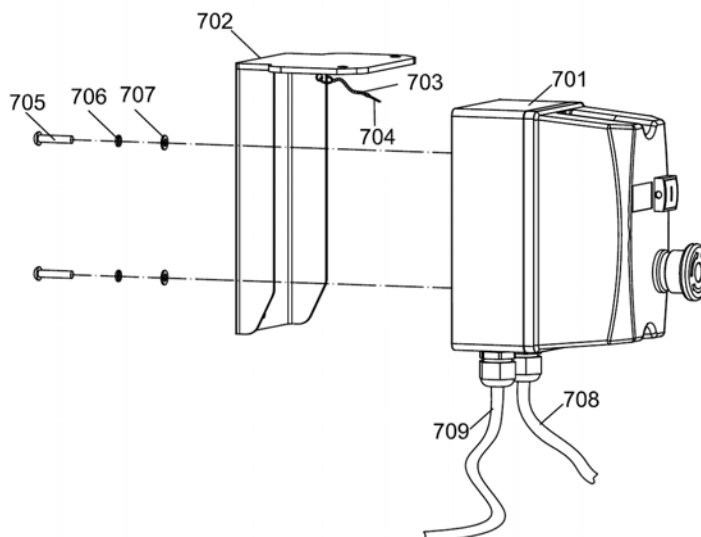

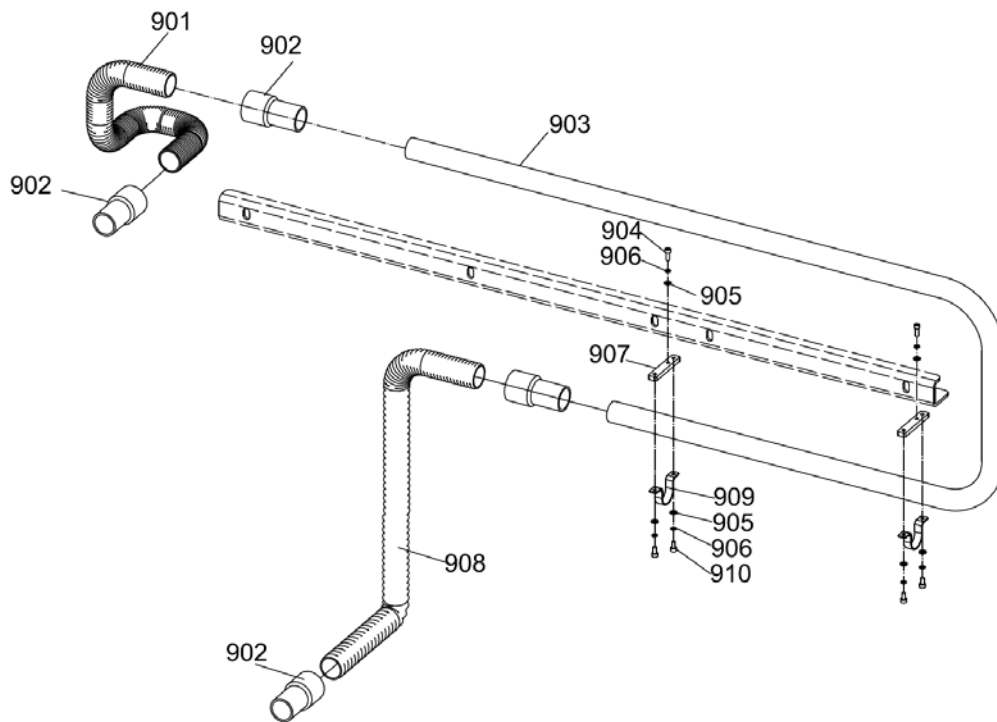

REF	DESCRIPTION	REF	DESCRIPTION
701	Switch	706	Lock washer 5
702	Switch bracket	707	Flat washer 5
703	Chain	708	Cable for power supply
704	Safety pin	709	Cable for motor
705	Pan HD screw M5-0.8x16		

Over Arm Exploded View



REF	DESCRIPTION	REF	DESCRIPTION
901	Flexible hose (1-1/2" 0.8m)	906	Lock washer 6
902	Hose Connector 1-1/2"	907	Bracket
903	Over arm	908	Flexible hose (1-1/2" 1m)
904	Cap screw M6-1x16	909	Clamp
905	Flat washer 6	910	Cap screw M6-1x12

11. Certificates

 Declaration of Conformity  (Manufacturer's Declaration)
We: Harvey Industries Co., Ltd. Guoshui Avenue, Shatou Town, Guangling District, Yangzhou 225000, P.R. China
Produce: Table Saw Model: HW110C-36
<i>to which this declaration applies, complies with the following directives and/or standards:</i>
2006/42/EC 2006/95/EC 2002/96/EC 2004/108/EC EN 60204-1:2006+A1:2009 EN 60335-2-69:2012 EN 1870-19:2003
<u>Notes:</u> This declaration becomes invalid, if technical or operational modifications are introduced without the manufacturers consent.
<u>Notes:</u> This declaration becomes invalid, if technical or operational modifications are introduced without the manufacturers consent.
Person responsible for keep the technical file:
Person responsible for making this declaration:
Name and signature: Kelvin.qin(秦晓钢) 
Date and place: <u>2019-06-11 Naniing</u>
Title of signature: R&D Manager

Certificate



Certificate no.

CA 72193609 01

License Holder:

Harvey Industries Co., Ltd.
01 Building, No.68 Suyuan
Road, Jiangning Economic &
Technological Development Zone
Nanjing 211100
China

Manufacturing Plant:

Harvey Industries Co., Ltd.
01 Building, No.68 Suyuan
Road, Jiangning Economic &
Technological Development Zone
Nanjing 211100
China

Test report no.: USA-SS 50241785 001

Client Reference: Qin Xiaogang

Tested to: CAN/CSA-C22.2 No. 62841-1-15 + GI1 + GI2
CSA C22.2 62841-3-1:2016+GI1

Certified Product: Table Saw

License Fee - Units

Model Designation: 1)HW110LC-36, 2)HW110S-36,HW110S-52

7

Ratings: 1)115V/230V, 60Hz, 1.5kW
2)230V, 60Hz, 3kW

Appendix: 1,1-4

7

Licensed Test mark:



Date of Issue

(day/mo/yr)

19/11/2019

Certificate



Certificate no.

TU 72193468 01

License Holder:

Harvey Industries Co., Ltd.
01 Building, No.68 Suyuan
Road, Jiangning Economic &
Technological Development Zone
Nanjing 211100
China

Manufacturing Plant:

Harvey Industries Co., Ltd.
01 Building, No.68 Suyuan
Road, Jiangning Economic &
Technological Development Zone
Nanjing 211100
China

Test report no.: USA-SS 50241785 001

Client Reference: Qin Xiaogang

Tested to: UL 62841-1:2015 R4.18
UL 62841-3-1:2016 R9.17

Certified Product: Table Saw

License Fee - Units

Model Designation: 1)HW110LC-36, 2)HW110S-36,HW110S-52

7

Ratings: 1)115V/230V, 60Hz, 1.5kW
2)230V, 60Hz, 3kW

Appendix: 1,1-4

7

Licensed Test mark:



Date of Issue
(day/mo/yr)

19/11/2019



Harvey Industries Co., Ltd

68-10 Suyuan Avenue, Jiangning District, Nanjing 211100, China
www.harveywoodworking.com

Harvey Industries International Inc.

10832 Ada Ave. Montclair, CA 91763, United States
TEL: 1-888-211-0397
E-mail: info@harveywoodworking.com

南京海威机械有限公司

中国南京江宁经济开发区苏源大道68-10
www.harvey.cn